

EXLIM Q

Surge Arrester - System Voltage 2 to 420 kV

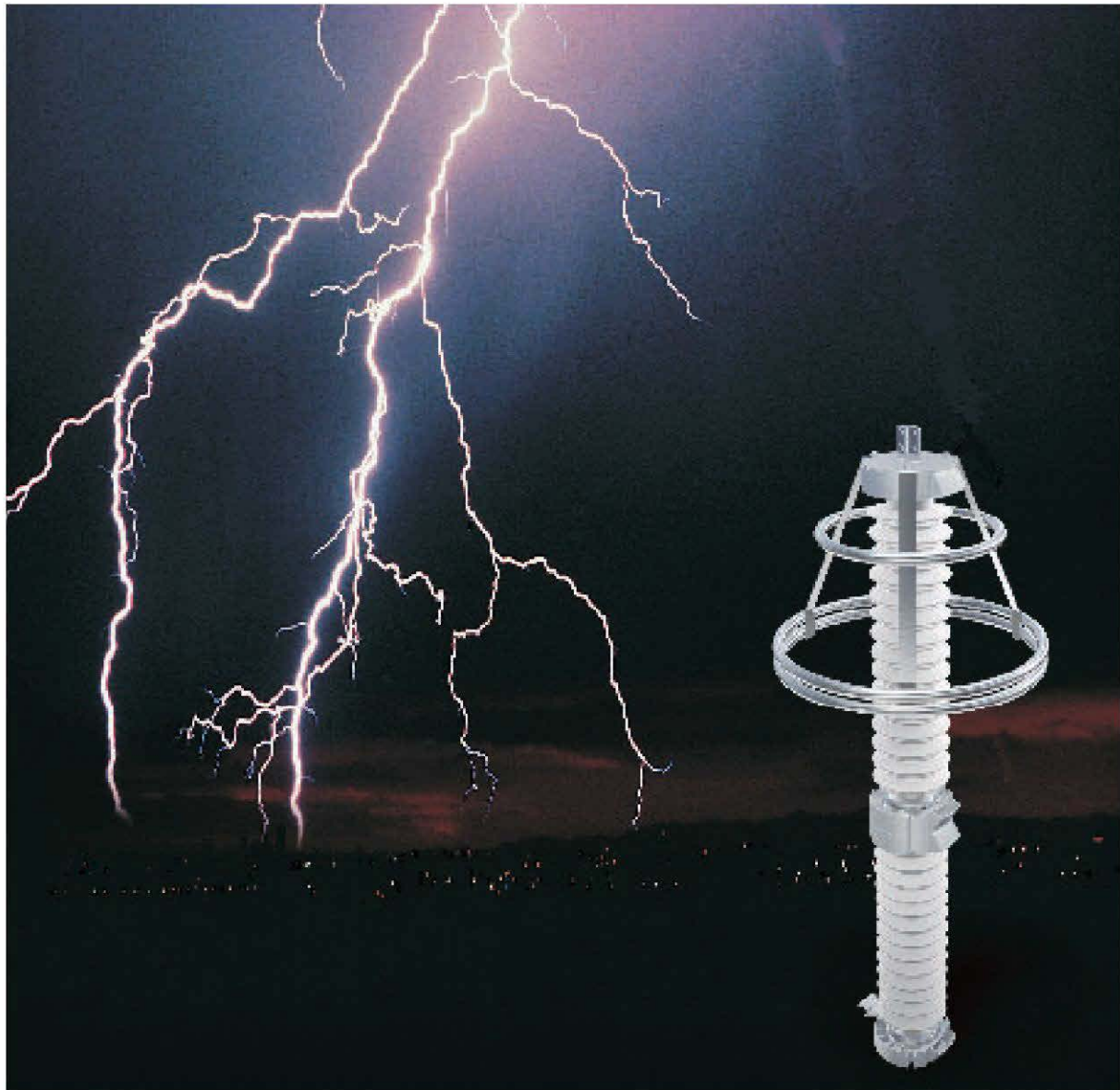

ABB

Metal Oxide Surge Arrester EXLIM Q



Protection of switchgear, transformers and other equipment in high voltage systems against atmospheric and switching overvoltages. For use when requirements of lightning intensity, energy capability and pollution are moderate.

Application

The Exlim Q gapless metal oxide arrester meets or exceeds all Station Class requirements of ANSI C62.11 (IEEE Standards for Metal Oxide Surge Arresters for AC Power Circuits). The EXLIM Q arrester is designed to meet the following performance data:

Performance data

Maximum system voltages (V_{M1})	2.52 - 120 kV _{rms}
Duty cycle rated voltages (V_r)	3 - 336 kV _{rms}
Classifying current (ANSI/IEEE)	10 kA peak
Discharge current withstand strength:	
High current 4/10 μ s	100 kA peak
Low current 2000 μ s	900 A peak
Energy capability:	
2 impulses, (IEC Cl. 7.5.5)	9.8 kJ / kV of MCOV
Fulfills requirements of ANSI transmission-line discharge test for 420 kV systems.	
Short-circuit / Pressure relief capability:	
Ratings 3 - 39 kV	65 kA rms sym
Ratings 45 - 336 kV	80 kA rms sym
Cantilever strength (DIN 48113)	5530 ft - lbs / 7500 Nm
Service conditions:	
Ambient temperature	-40 °C to + 45 °C
Design altitude	6000 ft / 1830 m
Frequency	15 - 62 Hz

1) Higher strength designs available on request

2) Higher altitude designs available on request

Nameplate

ABB		ABB Inc.	
TYPE EXLIM STATION CLASS SURGE ARRESTER			
STYLE NO.	SERIAL NO.	PRESSURE RELIEF CLASS	
RATING		MCOV RATING	WEIGHT
UNIT STACKING ORDER		MCOV KV	ALTITUDE 6000 Ft.
NOTION THIS UNIT	UNIT STYLE NO.	UNIT SERIAL NO.	GRADING RING ASSEMBLY
2ND			
3RD			
BEFORE INSTALLING READ INSTRUCTIONS IL 38-336-1		MADE IN U.S.A.	

Outlines

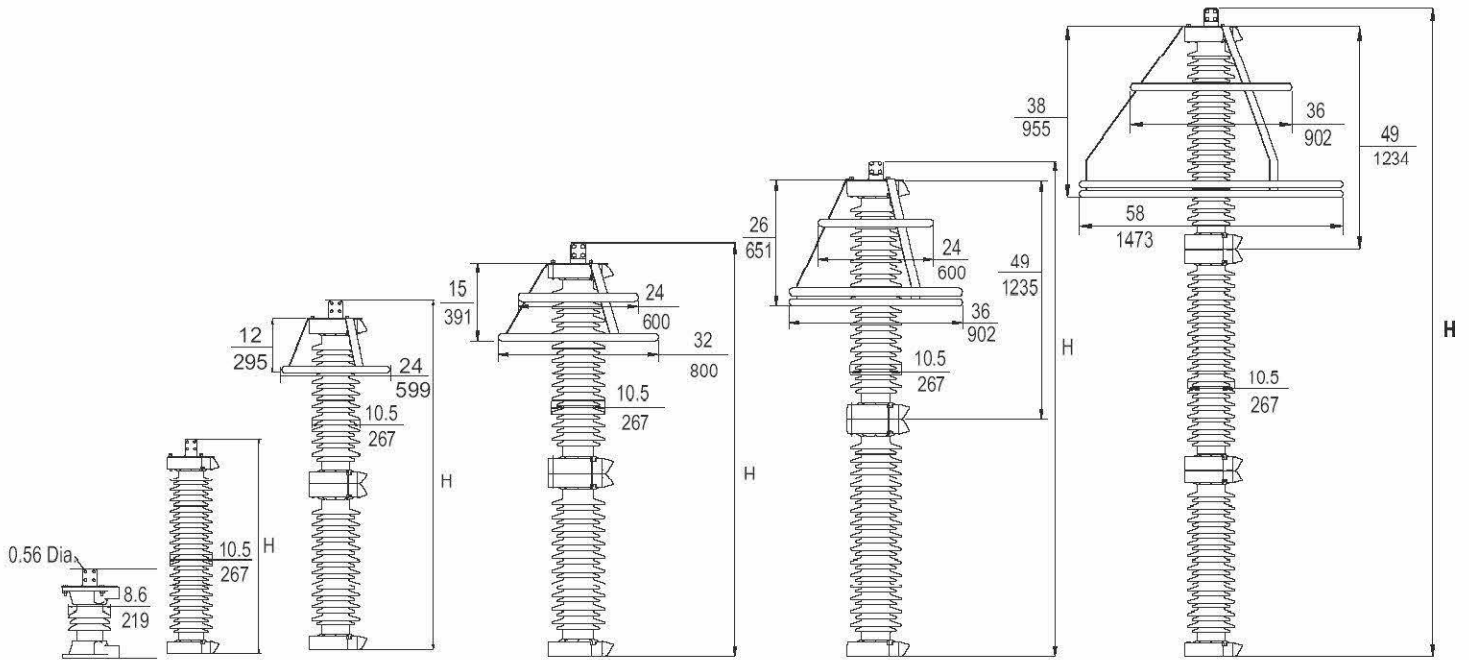

Figure 1

Figure 2

Figure 3

Figure 4

Figure 5

Figure 6

Guaranteed Performance Data

Power frequency voltage, kV rms						Maximum residual voltage with current wave, kV peak						
Nom. V_n (1)	Max. V_m (2)	Rating V_r (3)	MCOV (4)	TOV (5)		SPL (6) 30/60 μ s	LPL (7) 8/20 μ s					FOW (8) 0.5 μ s 10 kA
				1 s	10 s		3 kA	5 kA	10 kA	20 kA	40 kA	
2.40	2.52	3	2.55	5.26	5.04	9.27	10.4	10.8	11.3	12.5	13.9	12.3
4.16	4.37	3	2.55	5.26	5.04	9.27	10.4	10.8	11.3	12.5	13.9	12.3
4.16	4.37	6	5.10	7.17	6.84	12.3	13.8	14.3	15.0	16.5	18.5	17.1
4.80	5.04	6	5.10	7.17	6.84	12.3	13.8	14.3	15.0	16.5	18.5	17.1
6.90	7.24	6	5.10	7.17	6.84	12.3	13.8	14.3	15.0	16.5	18.5	17.1
6.90	7.24	9	7.65	10.5	10.0	18.6	20.8	21.5	22.6	24.9	27.8	24.5
6.90	7.24	10	8.40	11.7	11.2	20.4	24.4	25.2	25.0	29.2	32.6	28.7
8.32	8.73	6	5.10	7.17	6.84	12.3	13.8	14.3	15.0	16.5	18.5	17.1
8.32	8.73	9	7.65	10.7	10.2	18.5	20.8	21.5	22.6	24.9	27.8	24.4
8.32	8.73	10	8.40	11.9	11.4	20.4	23.0	23.8	25.0	27.5	30.8	27.0
8.32	8.73	12	10.2	14.0	13.4	24.6	27.6	28.5	30.0	32.9	36.9	34.2
12.0	12.6	9	7.65	10.7	10.2	18.5	20.8	21.5	22.6	24.9	27.8	24.4
12.0	12.6	10	8.40	11.9	11.4	20.4	23.0	23.8	25.0	27.5	30.8	27.0
12.0	12.6	12	10.2	14.3	13.6	24.6	27.6	28.5	30.0	32.9	36.9	34.2
12.0	12.6	15	12.7	17.5	16.8	30.7	34.5	35.9	37.5	41.3	46.2	40.5
12.47	13.10	9	7.65	10.7	10.2	18.5	20.8	21.5	22.6	24.9	27.8	24.4
12.47	13.10	10	8.40	11.9	11.4	20.4	23.0	23.8	25.0	27.5	30.8	27.0
12.47	13.10	12	10.2	14.3	13.6	24.6	27.6	28.5	30.0	32.9	36.9	34.2
12.47	13.10	15	12.7	17.9	17.1	30.7	34.5	35.6	37.5	41.3	46.1	40.5
12.47	13.10	18	15.3	21.5	20.5	36.9	41.4	42.8	45.0	49.3	55.4	51.3
13.2	13.9	10	8.40	11.9	11.4	20.4	23.0	23.8	25.0	27.5	30.8	27.0
13.8	14.5	12	10.2	14.3	13.6	24.6	27.6	28.5	30.0	32.9	36.9	34.2
13.8	14.5	15	12.7	17.9	17.1	30.7	34.5	35.6	37.5	41.3	46.1	40.5
13.8	14.5	18	15.3	21.5	20.5	36.9	41.4	42.8	45.0	49.3	55.4	51.3
20.78	21.8	15	12.7	17.9	17.1	30.7	34.5	35.6	37.5	41.3	46.1	40.5
20.78	21.8	18	15.3	21.5	20.5	36.9	41.4	42.8	45.0	49.3	55.4	51.3
20.78	21.8	21	17.0	24.5	23.5	41.4	46.4	48.2	50.4	55.5	62.0	51.7
20.78	21.8	24	19.5	28.0	26.8	47.1	52.9	54.7	57.6	63.4	70.8	62.2
20.78	21.8	27	22.0	31.5	30.2	53.2	59.7	61.9	64.8	71.3	79.8	70.4
22.86	24.00	18	15.3	21.5	20.5	36.9	41.4	42.8	45.0	49.3	55.4	51.3
23.00	24.15	21	17.0	25.0	23.9	41.4	46.4	48.2	50.4	55.5	62.0	54.7
23.00	24.15	24	19.5	28.7	27.4	47.1	52.9	54.7	57.6	63.4	70.8	62.2
23.00	24.15	27	22.0	31.5	30.2	53.2	59.7	61.9	64.8	71.3	79.8	70.4
23.00	24.15	30	24.4	35.1	33.6	59.1	66.3	68.4	72.0	79.2	88.6	77.8
24.94	26.19	18	15.3	21.5	20.5	36.9	41.4	42.8	45.0	49.3	55.4	51.3
24.94	26.19	21	17.0	25.0	23.9	41.4	46.4	48.2	50.4	55.5	62.0	54.7
24.94	26.19	24	19.5	28.7	27.4	47.4	52.9	54.7	57.6	63.4	70.8	62.2
24.94	26.19	27	22.0	31.5	30.2	53.2	59.7	61.9	64.8	71.3	79.8	70.4
24.94	26.19	30	24.4	35.8	34.2	59.1	66.3	68.8	72.0	79.2	88.6	78.2
24.94	26.19	36	29.0	42.1	40.3	70.9	79.5	82.1	86.4	95.1	107	93.4
34.5	36.2	27	22.0	31.5	30.2	53.2	59.7	61.9	64.8	71.3	79.8	70.4
34.5	36.2	30	24.4	35.8	34.2	59.1	66.3	68.8	72.0	79.2	88.6	78.2
34.5	36.2	36	29.0	43.0	41.0	70.9	79.5	82.6	86.4	95.1	107	93.8
34.5	36.2	39	31.5	45.6	43.6	76.8	86.2	89.0	93.6	103	116	102
34.5	36.2	45	36.5	52.6	50.4	88.6	99.4	103	108	119	133	117
46.0	48.3	36	29.0	43.0	41.0	70.9	79.5	82.6	86.4	95.1	107	93.8
46.0	48.3	39	31.5	46.6	44.4	76.8	86.2	89.4	93.6	103	116	102

Power frequency voltage, kV rms						Maximum residual voltage with current wave, kV peak						
Nom. V _n (1)	Max. V _m (2)	Rating V _r (3)	MCOV (4)	TOV (5)		SPL (6) 30/60 μs	LPL (7) 8/20 μs					FOW (8) 0.5 μs 10 kA
				1 s	10 s		3 kA	5 kA	10 kA	20 kA	40 kA	
46.0	48.3	45	36.5	53.7	51.3	88.6	99.4	104	108	119	133	118
46.0	48.3	48	39	56.1	53.7	94.5	106	110	116	127	142	125
46.0	48.3	54	42	63.1	60.4	107	120	124	130	143	160	140
46.0	48.3	60	48	70.2	67.2	119	133	137	144	159	178	156
46.0	48.3	72	57	84.2	80.6	142	161	167	174	191	215	189
69	72.5	54	42	64.5	61.5	107	120	124	130	143	160	140
69	72.5	60	48	71.7	68.4	119	133	138	144	159	178	157
69	72.5	72	57	86.0	82.0	139	161	167	174	191	215	189
69	72.5	90	70	105	100	178	199	206	216	238	266	234
69	72.5	96	76	112	107	189	212	219	231	254	284	249
115	123	90	70	107	102	173	199	207	216	238	266	235
115	123	96	76	114	109	189	213	221	231	255	285	251
115	123	108	84	126	120	213	239	247	260	286	319	280
115	123	120	98	140	134	237	265	274	288	317	355	312
115	123	132	106	154	147	261	292	301	317	349	390	343
115	123	144	115	168	161	285	318	329	346	381	426	374
138	145	108	84	126	120	213	239	247	260	286	319	280
138	145	120	98	143	136	236	265	276	288	317	355	313
138	145	132	106	157	150	261	292	303	317	349	390	344
138	145	144	115	172	164	285	319	331	346	381	426	376
138	145	168	131	200	191	332	364	376	404	435	486	427
161	170	132	106	157	150	261	292	303	317	349	390	344
161	170	144	115	172	164	285	319	331	346	381	426	376
161	170	168	131	196	188	332	371	384	404	444	496	436
161	170	172	140	203	194	351	385	397	418	460	514	452
161	170	180	144	210	201	363	398	411	432	476	532	467
161	170	192	152	224	215	388	424	438	461	507	567	498
230	245	180	144	215	205	363	398	411	432	476	532	467
230	245	192	152	229	218	388	424	438	461	507	567	498
230	245	228	180	266	255	460	504	520	548	602	674	591
230	245	240	190	280	268	484	530	548	576	634	709	623
345	362	258	209	301	288	542	570	589	620	682	762	669
345	362	264	212	308	295	555	583	602	634	697	780	685
345	362	276	220	322	309	580	610	630	663	729	815	716
345	362	288	230	336	322	605	636	657	692	761	851	747
345	362	294	235	343	329	618	650	671	706	777	868	763
345	362	312	245	365	349	656	689	712	749	824	922	809
400	420	330	267	386	369	693	729	753	792	872	975	856
400	420	336	272	393	376	706	742	767	807	888	992	871

- (1) V_n = Nominal System Voltage per ANSI C84.1
- (2) V_m = Maximum System Voltage per ANSI C84.1
- (3) V_r = Duty Cycle Rated Voltage per ANSI C62.11
- (4) MCOV = Maximum Continuous Operating Voltage per ANSI C62.11
- (5) TOV = Temporary Overvoltage with No Prior Energy
- (6) SPL = Switching Protective Level
500 A 3 - 132 kV
1,000 A 144 - 240 kV
2,000 A 258 - 336 kV
- (7) LPL = Lightning Protective Level

Technical data for housings

Rating V _r	Style No.	Height H		Creepage		Weight		Phase to Ground S		Phase to Phase T		Figure
		in	mm	in	mm	lb	kg	in	mm	in	mm	
3	Q003MA002A	17	431	7.4	187	38	17	8	203	14	356	1
6	Q006MA005A	17	431	7.4	187	39	18	9	229	14	356	1
9	Q009MA008A	19	482	15	381	45	20	9	229	15	381	1
10	Q010MA008A	19	482	15	381	45	20	10	254	15	381	1
12	Q012MA010A	19	482	15	381	46	21	11	279	15	381	1
15	Q015MA012A	23	584	24	609	55	25	12	305	16	406	1
18	Q018MA015A	23	584	24	609	56	25	13	330	17	432	1
21	Q021MA017A	23	584	24	609	57	26	14	356	18	457	1
24	Q024MA019A	23	584	24	609	58	26	15	381	19	483	1
27	Q027MA022A	27	685	39	990	72	33	16	406	20	508	1
30	Q030MA024A	27	685	39	990	74	34	17	432	21	533	1
36	Q036MA029A	27	685	39	990	75	34	19	483	23	584	1
39	Q039MA031A	27	685	39	990	76	35	19	483	24	610	1
45	Q045XA037A	29	737	56.8	1442	106	48	20	508	24	610	2
48	Q048XA039A	29	737	56.8	1442	107	49	20	508	25	635	2
54	Q054XA042A	29	737	56.8	1442	108	49	21	533	25	635	2
60	Q060XA048A	40	1016	91.3	2319	128	58	21	533	26	660	2
72	Q072XA057A	40	1016	91.3	2319	136	62	22	559	27	686	2
90	Q090XA070A	40	1016	91.3	2319	143	65	26	660	32	813	2
96	Q096XA076A	45	1143	107	2738	163	74	28	711	34	864	2
108	Q108XA084A	53	1346	133	3395	206	93	32	813	38	965	2
110	Q110XA088A	53	1346	133	3395	207	94	33	838	39	991	2
120	Q120XA098A	53	1346	133	3395	212	96	35	889	42	1067	2
132	Q132XA106A	53	1346	133	3395	224	102	39	991	45	1143	2
144	Q144XA115A	65	1651	148	3759	249	113	50	1270	62	1575	3
168	Q168XA131A	76	1930	182	4622	266	121	57	1448	69	1753	3
172	Q172XA140A	76	1930	182	4622	300	136	58	1473	71	1803	3
180	Q180XA144A	81	2068	199	5054	310	141	65	1651	81	2057	4
192	Q192XA152A	81	2068	199	5054	320	145	69	1753	85	2159	4
228	Q228XA180A	94	2385	241	6121	349	159	81	2057	99	2515	5
240	Q240XA190A	101	2576	267	6781	369	168	85	2159	103	2616	5
258	Q258XA209A	101	2576	267	6781	378	172	90	2286	108	2743	5
264	Q264XA212A	119	3019	298	7569	482	219	104	2642	121	3073	6
276	Q276XA220A	119	3019	298	7569	486	221	108	2743	137	3480	6
288	Q288XA230A	119	3019	298	7569	496	225	111	2819	140	3556	6
294	Q294XA235A	123	3112	306	7772	506	230	113	2870	142	3607	6
300	Q300XA240A	123	3112	306	7772	516	235	115	2921	144	3658	6
312	Q312XA245A	143	3620	375	9525	548	249	119	3023	148	3759	6
336	Q336XA272A	143	3620	375	9525	556	253	126	3200	155	3937	6

- 1) Increase clearances "S" and "T", 3% per each 1000 ft / 305 m over 6000 ft 1830 m
- 2) Arrester assembly consists of arrester unit, line, ground terminals and grading rings for ratings 144 kV and above
- 3) Minimum dimensions for arresters, other apparatus standards and other specifications or local codes may require greater spacing
- 4) Line and ground terminals can accommodate Cu or Al cable size Number 2 to 1000 MCM, (0.25 / 6.35 mm to 1.19 in / 30 mm diameter)
- 5) Height accuracy is: 3 - 132 kV +/- 1 in, 144 - 258 kV +/- 2 in, 264 - 336 kV +/- 3 inches

Standard Hardware

Line terminal

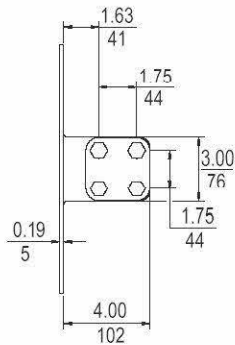

Ground terminal

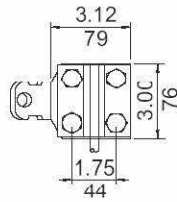

Drilling plan

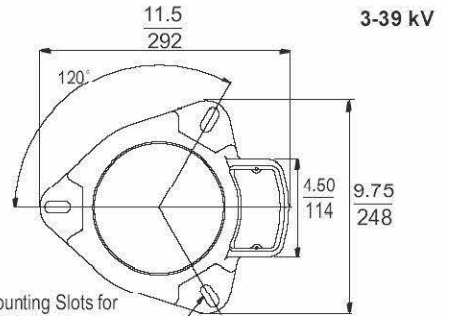

Mounting Slots for 0.50" Dia. Hardware (3) Equally Spaced on 8.75" to 10.0" Dia. B.C. Thickness of Lug = 0.75"

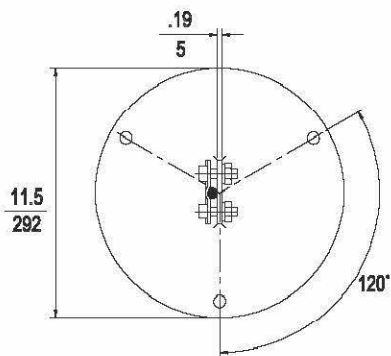

45-336 kV

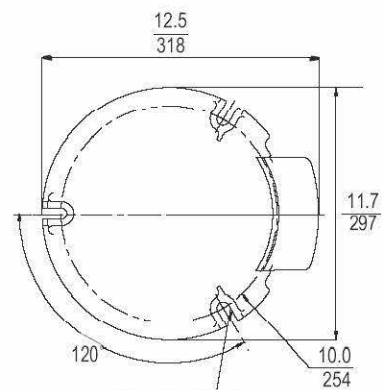

Mounting Slots for 0.50" Dia. Hardware (3) Equally Spaced on 10.0" Dia. B.C. Thickness of Lug = 2.44"

1) Line and ground terminals can accommodate copper or aluminum cable size Number 2 to 1000 MCM / 0.25 to 1.19 in / 6 to 30 mm diameter. Ground terminal can be located on any lug.

All Ratings

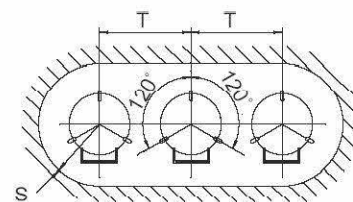

3 Ø Installation Layout