



Rotary switches for circuit breaker control, motor control or instrument transfer.

Features and Benefits

- Compact design
- Up to 10 stages (20 contacts)
- Double surface cams (one cam per contact)
- Add-a-stage feature for adding up to two stages
- Electrically separate and mechanically independent double-break contacts
- Standard mounts on panels up to 1/4" (up to 1.5" available)
- Rated 600 V, 20 A continuous
- Silver to silver positive wiping action contacts
- Pull-to-lock action available
- Up to 8 positions, 360° rotation
- 3 types of escutcheons (switch face plates)
- 8 types of fixed handles
- 3 types of removable handles
- Handles to match SB-1 available
- Maintained or spring return switch action

- UL recognized

Applications

- Control of electric-operated circuit breakers, valves, motors, etc.
- Transfer current and potential to instruments and relays
- Limited space applications



Design Information

The SBM switch is a rotary cam-operated device for panel mounting **only** and for applications where space is at a premium.

The standard line of switches is suitable for mounting on panels up to and including 1/4". Switches may be specially ordered for 1 and 1 1/2" mounting. The compact design and the angled terminal connections allow centerline-to-centerline mounting of only three inches.

The SBM switch consists of an operating handle and square shaft, an escutcheon plate, a positioning chamber, a front support, and a series of individual stages each nestled into the other forming its own enclosure. Each stage houses two electrically separate and mechanically independent double-break contacts. The contacts have a positive wiping action of silver-to-silver contact buttons. Double-break design reduces arcing and subsequent pitting of the contacts.

This compact design has the following features:

- a. **maximum of 10 stages** (20 contacts)
- b. **double-surface cams:**
one cam for each contact – one surface for **opening**, the other surface for **closing**; opening and closing action **does not depend on springs**
- c. **self-enclosed stages:**
eliminates the need for a separate cover; a small opening is provided at the bottom of each stage for quick contact inspection
- d. **maximum of eight positions:**
45 and 90° between positions
- e. **eight types of fixed, black handles:**
knurled, oval, radial, round, lever and three types pistol grip (small, large)

- f. **three types of removable handles:**
pistol, oval, and knurled (SBM or SB-1 types)
- g. **three types of escutcheons:**
 1. standard (8 positions)
 2. target with red and green indicators
 3. modified standard for removable handles
- h. **two types of operation:**
 1. maintained action – all positions
 2. spring return action is limited to 90° clockwise and counter-clockwise of the 12 o'clock position; spring return action can be furnished from both sides to 12 o'clock or from one side only with maintained action on the opposite side
- j. **special mechanisms:**
 - a. add-a-stage
 - b. pull-to-lock
- k. **special enclosures:**
none available

Add-A-Stage Feature

A maximum of two additional stages (4 contacts) may be easily and economically added to an existing **SBM** switch.

A 1/2" extension is provided on the rear of SBM switches with one to eight stages only. This extension permits the coupling of the "add-a-stage" unit when additional contacts are required.

Add-A-Stage Units

- No. 888B212G1 - 2 contacts
- No. 888B212G2 - 1 contact
- No. 888B212G3 - 4 contacts
- No. 888B212G4 - 3 contacts

NOTE: Specify catalog number of original switch and the position(s) in which each adder contact is to close. Instruction Book GEI-68767 provides information on mounting the add-a-stage unit.

Ratings

The electrical ratings are 600 VDC or VAC, 20 A continuous. The interrupting rating depends upon the voltage and character of the circuit. The table below illustrates the interrupting duty of a single contact and contacts in series when various conditions exist on a circuit.

Interrupting Ratings

Circuit Volts	Noninductive Circuit		Inductive Circuit	
	Number of Contacts			
	1	2 in series	1	2 in circuit
24 DC	10	30	8	25
48 DC	8	25	6	18
125 DC	5	15	4	10
250 DC	1	3	1	2.5
600 DC	.4	.8	.3	.7
115 AC	40	75	24	50
230 AC	25	50	12	25
460 AC	20	30	10	20
600 AC	15	25	8	12

Model Switch Listings

“Listed” switches are shown on these pages. Any change in the characteristics such as contact arrangement, position location, handle type, or escutcheon engraving from those shown on these pages will cause the switch to be placed on the “unlisted” line of switches.

Service, Poles, and Throws	Model No.	Stages
VOLTMETER		
DP-ST	AA001	1
DP-DT	AA002	2
3φ 4W phase-to-neutral	AA003	2
3φ 4W phase-to-phase or phase-to-neutral	AA004	2
4 circuits 2 wiresAA005	4	
3φ 4W phase-to-phase and phase-to-neutral	AA006	3
2 – 3φ. 3W circuits	AA007	4
AMMETER		
3 CT'S (end of secondary)	AA008	3
3 CT'S (end of secondary) & off	AA009	3
3 independent circuits	AA010	5
2 CT'S (end of secondary)	AA011	2
2 CT'S (end of secondary) & off	AA012	2
3 independent circuits and off	AA013	5
AMMETER VOLTMETER		
3-phase 3W phase-to-phase, 3 independent circuits	AA014	7
3-phase 4W phase-to-neutral, 3 independent circuits	AA015	6
3-phase 3W phase-to-phase, 3 independent circuits, end of secondary	AA016	5
3-phase 4W phase-to-neutral, 3 independent circuits, end of secondary	AA017	5

Service, Poles, and Throws	Model No.	Stages
WATTMETER		
2 current coilsAA018	3	
3 current coilsAA019	5	
2 current and 2 potential coils	AA020	4
POWER FACTOR		
One or two CT coils	AA021	2
One CT and 2 PT coils	AA022	3
Reversing switchAA023	4	
MOTOR CONTROL		
Governor, rheostat	AA066	4
Stop, start, targetAA067	1	
For split-field motors	AA065	1
SYNCHRONIZING		
Machine to busAA024Δ	2	
Running and incoming	AA025Δ	2
Between machines	AA026Δ	2
BREAKER CONTROL		
Close and trip (target)	AA100	2
Close and trip and auxiliary contacts (target)	AA101	4
Trip, contacts normally open	AA102	1
Trip, contacts normally closed	AA103	1

Service, Poles, and Throws	Model No.	Stages
BREAKER CONTROL (cont.)		
Operate two breakers (target)	AA104	3
Substitute for P.B. switch (target)	AA105	2
Target	AA106	3
Target	AA107	1
Target	AA108	3
Target	AA109	4
Target	AA110	4
Target	AA111	5
Target	AA112	5
Target	AA113	5
With pull-to-lock (target)	AA114	2
With pull-to-lock (target)	AA115	3
With pull-to-lock (target)	AA116	3
With pull-to-lock (target)	AA117	4
With pull-to-lock (target)	AA118	4
With pull-to-lock (target)	AA119	4
With pull-to-lock (target)	AA120	4
With pull-to-lock (target)	AA121	4
With pull-to-lock (target)	AA122	4
With pull-to-lock (target)	AA123	5
With pull-to-lock (target)	AA124	5

Δ Removable handle required with switch. Refer to GET-6169 for type of handle. Order as separate item.

Model Switch Listings

Service, Poles, and Throws		Model No.	Stages
MISCELLANEOUS SWITCHES			
S or DP-ST	Maintained	AA027	1
	Spring return	AA028	1
3 or 4P-ST	Maintained	AA029	2
	Spring return	AA030	2
5 or 6P-ST	Maintained	AA031	3
	Spring return	AA032	3
7 or SP-ST	Maintained	AA033	4
	Spring return	AA034	4
9 or 10P-ST	Maintained	AA035	5
	Spring return	AA036	5
11 or 12P-ST	Maintained	AA037	6
	Spring return	AA038	6
SP-DT with off,	Maintained	AA039	1
	Spring return	AA040	1
DP-DT with off,	Maintained	AA041	2
	Spring return	AA042	2
3P-DT with off,	Maintained	AA068	3
	Spring return	AA043	3
4P-DT with off,	Maintained	AA044	4
	Spring return	AA045	4

Service, Poles, and Throws		Model No.	Stages
MISCELLANEOUS SWITCHES (cont.)			
5P-DT with off,	Maintained	AA046	5
	Spring return	AA047	5
6P-DT with off,	Maintained	AA048	6
	Spring return	AA049	6
SP-DT		AA050	1
DP-DT		AA051	2
3P-DT		AA052	3
4P-DT		AA053	4
5P-DT		AA054	5
6P-DT		AA055	6
7P-DT		AA056	7
SP-3T		AA057	2
SP-4T		AA058	2
SP-5T		AA059	3
SP-6T		AA060	3
SP-7T		AA061	4
SP-8T		AA062	4
2P-4T		AA063	4
2P-8T		AA064	8

Jumpers

Jumpers are furnished assembled, where required, on all standard listed switches. For special switches or unlisted switches, separate jumpers can be ordered from the table below (to be assembled by purchaser). No additional charge for extra jumpers to be used on these switches.

It is recommended that the formed jumpers listed should be used wherever possible in preference to wire jumpers to accomplish the various electrical connections that may be required. Also, the formed jumper will provide greater flexibility when adapting the SBM switch to individual requirements.

Jumpers ordered separately:
 Cat. No. 307V512P1 (Adjacent stage)
 Cat. No. 307V515P1 (Same stage)

Fig. 1. Jumper 307V512P1 (Adjacent stage)

Fig. 2. Jumper 307V515P1 (Same stage)



Selection Guide for Control and Transfer Switches

MODEL NUMBER	STAGE	HANDLE	ENGRAVING	SPECIAL FEATURES
AA001	1	K	OFF-ON	—
AA002	2	K	1-OFF-2	—
AA003	2	K	OFF-1-2-3	—
AA004	2	K	OFF-(1-2)-(2-3)-(3-1)	—
AA005	4	K	OFF-1-2-3-4	—
AA006	3	K	2-3-OFF-(1-2)-(2-3)-(3-1)-OFF-1	—
AA007	4	K	(2-3)-(3-1)-OFF-(1-2)-(2-3)-(3-1)-OFF-(1-2)	—
AA008	3	K	1-2-3	—
AA009	3	K	3-OFF-1-2	—
AA010	5	K	1-2-3	—
AA011	2	K	1-2-3	—
AA012	2	K	3-OFF-1-2	—
AA013	5	K	3-OFF-1-2	—
AA014	7	K	3-OFF-1-2	—
AA015	6	K	3-OFF-1-2	—
AA016	5	K	3-OFF-1-2	—
AA017	5	K	3-OFF-1-2	—
AA018	3	K	OFF-ON	—
AA019	5	K	OFF-ON	—
AA020	4	K	OFF-ON	—
AA021	2	K	OFF-ON	—
AA022	3	K	OFF-ON	—
AA023	4	K	IN-OUT	—
AA024	2	*23WW145	OFF-ON	*
AA025	2	*23WL235	R-OFF-I	**
		*23WR235		
AA026	2	*23WL123	R-(blank)-I	**
		*23WR123		

MODEL NUMBER	STAGE	HANDLE	ENGRAVING	SPECIAL FEATURES
AA027	1	V	OFF-ON	—
AA028	1	V	OFF-ON	—
AA029	2	V	OFF-ON	—
AA030	2	V	OFF-ON	—
AA031	3	V	OFF-ON	—
AA032	3	V	OFF-ON	—
AA033	4	V	OFF-ON	—
AA034	4	V	OFF-ON	—
AA035	5	V	OFF-ON	—
AA036	5	V	OFF-ON	—
AA037	6	V	OFF-ON	—
AA038	6	V	OFF-ON	—
AA039	1	V	1-OFF-2	—
AA040	1	V	1-OFF-2	—
AA041	2	V	1-OFF-2	—
AA042	2	V	1-OFF-2	—
AA043	3	V	1-OFF-2	—
AA044	4	V	1-OFF-2	—
AA045	4	V	1-OFF-2	—
AA046	5	V	1-OFF-2	—
AA047	5	V	1-OFF-2	—
AA048	6	V	1-OFF-2	—
AA049	6	V	1-OFF-2	—
AA050	1	V	1-2	—
AA051	2	V	1-2	—
AA052	3	V	1-2	—
AA053	4	V	1-2	—
AA054	5	V	1-2	—

Selection Guide for Control and Transfer Switches

MODEL NUMBER	STAGE	HANDLE	ENGRAVING	SPECIAL FEATURES
AA055	6	V	1-2	—
AA056	7	V	1-2	—
AA057	2	V	1-2-3	—
AA058	2	V	1-2-3-4	—
AA059	3	V	1-2-3-4-5	—
AA060	3	V	1-2-3-4-5-6	—
AA061	4	V	7-1-2-3-4-5-6	—
AA062	4	V	7-8-1-2-3-4-5-6	—
AA063	4	V	4-1-2-3	—
AA064	8	V	7-8-1-2-3-4-5-6	—
AA065	1	P	RAISE-(blank)-LOWER	—
AA066	4	L	RAISE-(blank)-LOWER	—
AA067	1	P	STOP-(blank)-START	—
AA068	3	V	1-OFF-2	—
AA069	2	*21WW236	OFF-(1-2)-(2-3)-(3-1)	*
AA070	3	*23WW458	OFF-ON	*
AA071	2	*23WW156	OFF-ON	*
AA072	3	*23WW156	OFF-ON	*
AA073	1	P	TRIP-NOR	—
AA074	2	P	TRIP-NOR	—
AA075	1	L	LOWER-(blank)-RAISE	—
AA076	1	V	LOWER-(blank)-RAISE	—
AA077	2	L	LOWER-(blank)-RAISE	—
AA078	2	V	LOWER-(blank)-RAISE	—
AA079	4	L	LOWER-(blank)-RAISE	—
AA080	4	V	LOWER-(blank)-RAISE	—
AA081	2	V	OFF-MOTOR-M&G	—
AA082	3	K	GEN-BATT-POS to GD-NEG to GD	—
AA083	4	V	MAN-AUTO	—
AA084	6	V	MAN-AUTO	—
AA085	8	V	MAN-AUTO	—
AA086	5	K	OFF-INT-ON	—
AA087	3	P	NEAR END-NOR-FAR END-DIFF	—
AA088	2	V	RS-REC-NOR SEND	—
AA089	4	V	CHANNEL ON-CHANNEL OFF	—

MODEL NUMBER	STAGE	HANDLE	ENGRAVING	SPECIAL FEATURES
AA090	2	V	NOR-TEST-OFF	—
AA091	2	V	OFF-ON	—
AA092	3	K	1-2-3-OFF	—
AA093	5	K	1-2-3-OFF	—
AA094	1	K	AUTO-MAN	—
AA100	2	P	TRIP-(blank)-CLOSE	—
AA101	4	P	TRIP-(blank)-CLOSE	—
AA102	1	P	(blank)-TRIP	—
AA103	1	P	(blank)-TRIP	—
AA104	3	P	TRIP-(blank)-CLOSE	—
AA105	2	P	TRIP-(blank)-CLOSE	—
AA106	3	P	TRIP-(blank)-CLOSE	—
AA107	1	P	TRIP-(blank)-CLOSE	—
AA108	3	P	TRIP-(blank)-CLOSE	—
AA109	4	P	TRIP-(blank)-CLOSE	—
AA110	4	P	TRIP-(blank)-CLOSE	—
AA111	5	P	TRIP-(blank)-CLOSE	—
AA112	5	P	TRIP-(blank)-CLOSE	—
AA113	5	P	TRIP-(blank)-CLOSE	—
AA114	2	P	PULL TO LOCK-TRIP-(blank)-CLOSE	PULL
AA115	3	P	PULL TO LOCK-TRIP-(blank)-CLOSE	PULL
AA116	3	P	PULL TO LOCK-TRIP-(blank)-CLOSE	PULL
AA117	4	P	PULL TO LOCK-TRIP-(blank)-CLOSE	PULL
AA118	4	P	PULL TO LOCK-TRIP-(blank)-CLOSE	PULL
AA119	4	P	PULL TO LOCK-TRIP-(blank)-CLOSE	PULL
AA120	4	P	PULL TO LOCK-TRIP-(blank)-CLOSE	PULL
AA121	4	P	PULL TO LOCK-TRIP-(blank)-CLOSE	PULL
AA122	4	P	PULL TO LOCK-TRIP-(blank)-CLOSE	PULL
AA123	5	P	PULL TO LOCK-TRIP-(blank)-CLOSE	PULL
AA124	5	P	PULL TO LOCK-TRIP-(blank)-CLOSE	PULL
AA125	1	P	TRIP-(blank)-CLOSE	—
AA126	2	P	TRIP-(blank)-CLOSE	—
AA127	2	P	TRIP-(blank)-CLOSE	—
AA128	2	P	TRIP-(blank)-CLOSE	—
AA129	4	P	TRIP-(blank)-CLOSE	—

Dimensions

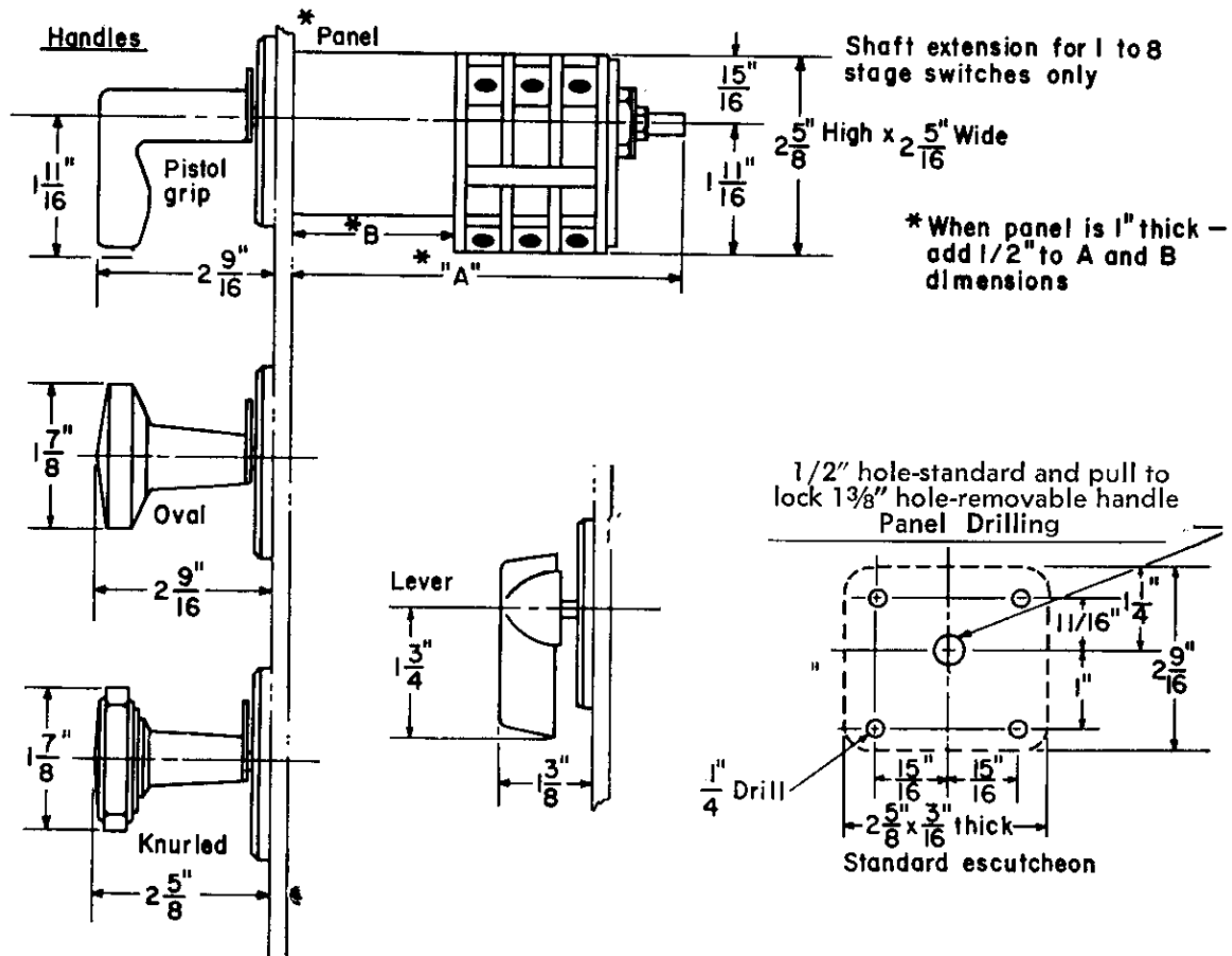

No. of Stages	Standard Switch		Pull-to-Lock Switch		Removable Handle Switch	
	"A"	B	"A"	B	"A"	B
1	3 7/8	2 1/8	4 9/16	2 7/8	4 3/4	3 1/16
2	4 1/2	2 1/8	5 7/16	2 7/8	5 3/4	3 1/16
3	5 1/8	2 1/8	5 13/16	2 7/8	6	3 1/16
4	5 3/4	2 1/8	6 7/16	2 7/8	6 5/8	3 1/16
5	6 3/4	2 1/8	7 1/16	2 7/8	7 1/4	3 1/16
6	7	2 1/8	7 11/16	2 7/8	7 1/8	3 1/16
7	7 5/8	2 1/8	8 5/16	2 7/8	8 1/2	3 1/16
8	8 1/4	2 1/8	8 15/16	2 7/8	9 1/8	3 1/16
9	8 1/2	2 1/8	8 3/16	2 7/8	9 1/8	3 1/16
10	9 1/8	2 1/8	9 13/16	2 7/8	9 3/4	3 1/16



Removable Handles

The SBM switch can be furnished with three types of removable handles: pistolgrip, oval, and knurled. When the SBM switch has maintained operation, the removable handle can be removed in any single one of the eight positions that are available on the switch.

When spring return operation is used then the handle is removable only in the normal or 12 o'clock position.

Typical handles that are removable in the 12 o'clock position are:

Knurled Cat. No. 13WW145

Oval Cat. No. 23WW145

Pistol Cat. No. 33WW145

Note: Removable handles are not included in the price of the switch. They must be ordered with the switch and listed as a separate item.

Shipping Weights

Type SBM (1 stage) @ 1 1/2 lbs Add 6 oz. for each additional stage.

Description of Action

Maintained Both Directions

- 1A - Positions 1, 2, 3, 4, 5, 6, 7, 8
- 2A - Positions 1, 3, 5, 7
- 3A - Positions 2, 4, 6, 8

Spring Return to Position 3 from Both Directions

- 1S - Positions 2, 4,
- 2S - Positions 1, 5
- 3S - Positions 1, 5, (Feel Position 2)
- 4S - Positions 1, 5, (Feel Position 4)
- 5S - Positions 1, 5, (Feel Positions 2 & 4)
- 1F - Pull to Lock in Position 1, (Feel Position 2)
- 2F - Pull to Lock in Position 2

Spring Return to Position 3 - From CW Only

- 1C - From Position 4
- 2C - From Position 5
- 3C - From Position 5, (Feel Position 4)

Spring Return to Position 3 - CCW Only

- 1W - From Position 2
- 2W - From Position 1
- 3W - From Position 1, (Feel Position 2)

Spring Return to Position 3 from CW Maintain Position at CCW

- 1H - From Position 4, Maintain Position 1, 2
- 2H - From Position 4, Maintain Position 1
- 3H - From Position 5, Maintain Position 2
- 4H - From Position 5, (Feel Pos. 4), Maintain Position 2
- 5H - From Position 5, Maintain Position 1
- 6H - From Position 5, (Feel Pos. 4), Maintain Position 1

Spring Return to Position 3 from CCW Maintain Position at CW

- 1K - From Position 2, Maintain Position 4, 5
- 2K - From Position 2, Maintain Position 5
- 3K - From Position 1, Maintain Position 4
- 4K - From Position 1, (Feel Pos. 2), Maintain Position 4
- 5K - From Position 1, Maintain Position 5
- 6K - From Position 1, (Feel Pos. 2), Maintain Position 5

Position diagram front view

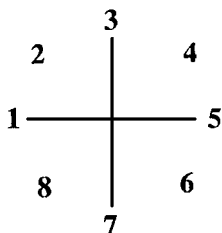

Selection Guide for Unlisted Switches

The guide below is for unlisted switches which are numbered at the factory. Use it only as a guide to identify catalog numbers assigned by the factory.

16SBM	*	*	***	*	*	*	*	*	***	
16SBM	A									1 stage
	B									2 stage
	C									3 stage
	D									4 stage
	E									5 stage
	F									6 stage
	G									7 stage
	H									8 stage
	K									9 stage
	L									10 stage
	2									2 positions
	3									3 positions
	4									4 positions
	5									5 positions
	6									6 positions
	7									7 positions
	8									8 positions
			***							Sequence number assigned by factory
				S						Standard escutcheon
				T						Target escutcheon
				P						Target (pull to lock) escutcheon
				N						No escutcheon
				R						Escutcheon with removable handle
						*				Insert action from "Description of Action" table at right
							*			Indicate 1st stop position
								K		Knurled handle
								V		Oval handle
								P		Pistol grip handle
								L		Lever handle
								A		SB 1 knurled handle
								B		SB 1 oval handle
								C		SB 1 pistol grip handle
								D		SB 1 round handle
								N		No handle
							1			Up to 1/4 inch
							2			1 or 1 1/2 inches
									***	When used, indicate escutcheon keyways