

RENEWAL PARTS

IC2820A102-A THRU BW AND CAT. NO. 228X275G1 THRU-G10 RELAYS

CAUTION: After replacing parts in the Cat. No. 228X275G1, -G2, -G3 or -G4 relay, be sure to test and adjust relay for pick-up current as specified on instruction sheet GEH-3072.

NOTE:—When ordering parts for a form of the relay not covered by this bulletin, give reference number, description of part, complete nameplate reading, and above bulletin (GEF) number. *Do not use catalog number when form for which the parts are needed is not covered by the bulletin.*

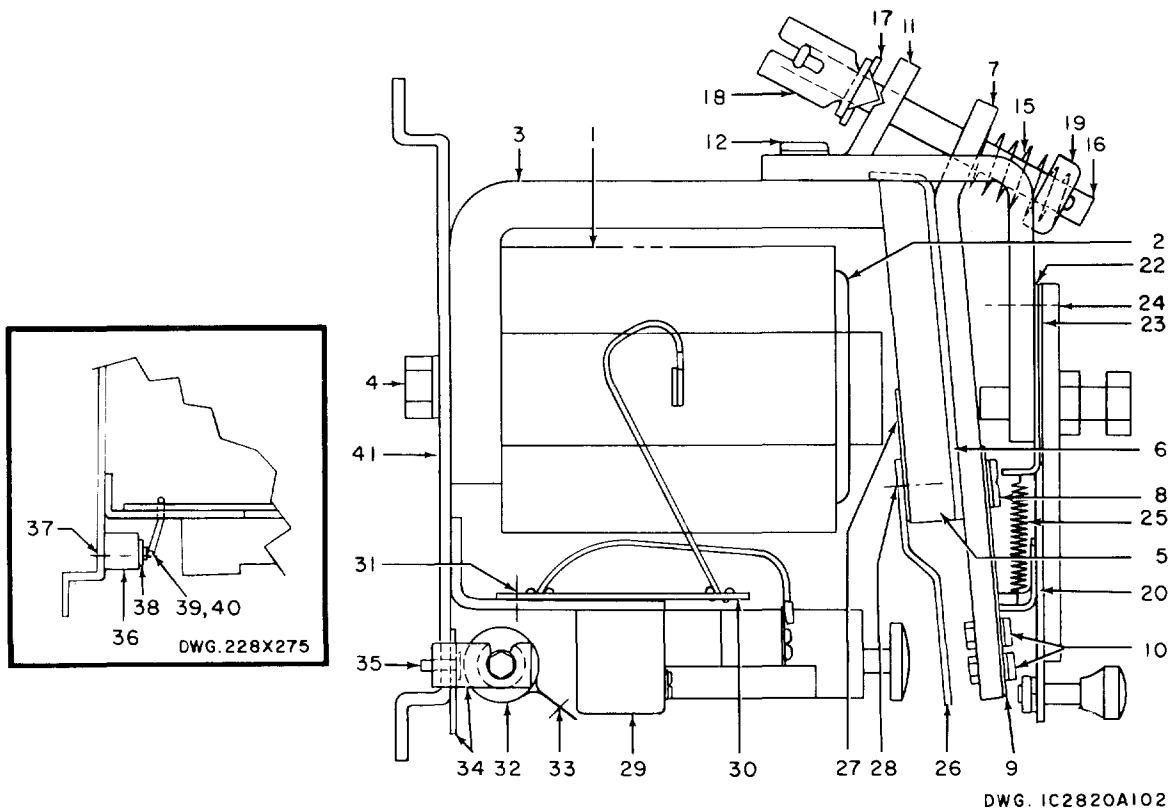

When ordering renewal parts, give quantity, catalog number, description of each item required, and complete nameplate reading.



Ref. No.	Number Required for IC2820-A102-																				Catalog Number	Description
	A, B C, D	E BE	F, AF AN, BF BN	G BG	H, AH AS, BH BS	J P	K AK	L AL BL	M AM	N	Q	R	S	T	U	W BW	X	Y	BK	BM		
24	2	2	2	2	2	2	2	2	2	2	2	2	2	2	2	2	2	2	2	2	N57P15010B6	Screw fastening latch bar, latch stop, and shim to armature stop plate (8-32, 5/8 in., pan hd, slot, pro fin)
25	1	1	1	1	1	1	1	1	1	1	1	1	1	1	1	1	1	1	1	1	*574A743P1	Tension spring for latch bar assembly
26	1	-	-	-	-	-	-	-	-	-	-	-	-	-	-	-	-	-	-	-	576A118P1	Operating arm for interlock
26	-	1	1	1	1	1	1	1	1	1	1	1	1	1	1	1	1	1	1	1	576A118P2	Operating arm for interlock
27	1	-	-	-	-	-	-	-	-	-	-	-	-	-	-	-	-	-	-	-	2450533	Shim for operating arm
28	2	2	2	2	2	2	2	2	2	2	2	2	2	2	2	2	2	2	2	2	N75P15006	Screw fastening interlock operating arm and shim to armature (8-32, 3/8 in., pan hd, slot, brass)
29	1	-	-	-	-	-	-	-	-	-	-	-	-	-	-	-	-	-	-	-	IC2956A200AS	Switch unit for Form A only
29	-	1	1	-	-	-	-	-	1	-	1	-	-	1	1	-	-	-	-	-	IC2956A200F	Switch unit for Forms E, F, M, Q, T, U only
29	-	-	-	1	1	-	1	-	-	-	-	-	-	-	-	-	-	-	-	-	IC2956A200D	Switch unit for Forms G, H, K only
29	-	-	-	-	-	1	-	-	-	-	-	1	-	-	-	1	1	1	-	-	IC2956A200E	Switch unit for Forms J, P, R, W, X, Y, BW only
29	-	-	-	-	-	-	1	-	1	-	-	-	-	-	-	-	-	-	-	-	IC2956A200BC	Switch unit for Forms L, N only
29	-	-	-	-	-	-	-	-	-	-	-	-	1	-	-	-	-	-	-	-	IC2956A200BK	Switch unit
29	-	1	1	-	-	-	-	-	1	-	-	-	-	-	-	-	-	-	1	-	IC2956A207D	Switch unit for Forms AE, AF, AM, BE, BF, BK only
29	-	-	-	1	1	-	1	-	-	-	-	-	-	-	-	-	-	-	-	1	IC2956A207E	Switch unit for Forms AG, AH, AK, BG, BH, BM only
29	-	-	1	-	-	-	-	1	-	-	-	-	-	-	-	-	-	-	-	-	IC2956A207F	Switch unit for Forms AL, AN, BL, BN only
29	-	-	-	-	1	-	-	-	-	-	-	-	-	-	-	-	-	-	-	-	IC2956A207G	Switch unit for Forms AS, BS only
	1	1	1	1	1	1	1	1	1	1	1	1	1	1	1	1	1	1	1	1	*6960053G37	Set of interlock contacts, with springs and contact-holding screws
	1	1	1	1	1	1	1	1	1	1	1	1	1	1	1	1	1	1	1	1	576A115P1	Mounting bracket for switch unit
	2	2	2	2	2	2	2	2	2	2	2	2	2	2	2	2	2	2	2	2	576A145P4	Screw fastening mounting bracket to base
	2	2	2	2	2	2	2	2	2	2	2	2	2	2	2	2	2	2	2	2	119A4655P5	Screw fastening mounting bracket to switch unit
30	1	1	1	1	1	1	1	-	1	-	1	1	-	1	1	-	1	1	-	-	*149B2816G1	Rectifier board assembly for Forms A, B, C, D, E, F, G, H, J, L, M, R, T, X, Y, Q, U, AE-AH, AK, AM only
30	-	-	1	-	1	1	-	1	-	1	-	-	1	-	-	-	-	-	-	-	*149B2816G2	Rectifier board assembly for Forms L, N, P, S, AL, AN, AS only
30	-	1	1	1	1	-	-	-	-	-	-	-	-	-	-	-	-	-	1	1	*177B8744G1	Rectifier board assembly for Forms BE-BK, BM only
30	-	-	1	-	1	-	-	1	-	-	-	-	-	-	-	-	-	-	-	-	*177B8744G2	Rectifier board assembly for Forms BL, BN, BS only
31	2	2	2	2	2	2	2	2	2	2	2	2	2	2	2	2	2	2	2	2	N57P15006B6	Screw fastening rectifier board assembly to interlock mounting bracket (8-32, 3/8 in., pan hd, slot, pro fin)
32	1	1	-	1	-	-	1	1	1	-	-	-	-	-	-	-	-	-	1	-	168A1796P1	Resistor
32	-	-	1	-	1	-	-	-	-	-	-	-	-	-	-	-	-	-	-	-	168A1796P1	Resistor for Forms BN, BS only
32	-	-	-	-	-	-	-	-	-	-	-	1	-	1	-	-	-	-	-	-	168A1796G3	Resistor
33	2	2	2	2	2	-	2	2	2	-	-	2	-	2	-	-	-	-	2	-	N57P13004B6	Screw for resistor terminal (6-32, 1/4 in., pan hd, slot, pro fin)
34	1	1	1	1	1	-	1	1	1	-	-	1	-	1	-	-	-	-	1	-	167A9933P1	Support for resistor
35	2	2	2	2	2	-	2	2	2	-	-	2	-	2	-	-	-	-	2	-	N144P15006B6	Screw with lock washer fastening support to base (8-32, 3/8 in., pan hd, pro fin)
36	1	-	-	-	-	-	-	-	-	-	-	-	-	-	-	-	-	-	-	-	167A5694P1	Base
36	-	1	1	1	1	1	1	1	1	1	1	1	1	1	1	1	1	1	1	1	167A5694P2	Base
	-	1	1	1	1	1	1	1	1	1	1	1	1	1	1	1	1	1	1	1	193A9123P1	Core head

* Parts recommended for normal stock.

Ref. No.	Number Required for IC2820-A102-																				Catalog Number	Description
	A, B C, D	E BE	F, AF AN, BF BN	G AG BG	H, AH AS, BH BS	J P	K AK	L AL BL	M AM	N	Q	R	S	T	U	W BW	X	Y	BK	BM		
1	1	1	-	1	-	-	1	1	1	-	-	-	-	-	-	-	-	-	-	-	*22D11G267A	Operating coil
1	-	-	-	-	-	1	-	-	-	-	-	-	-	-	-	-	-	-	-	-	*22D11G128A	Operating coil
1	-	-	-	-	-	-	-	-	-	-	1	-	1	-	-	-	-	-	-	-	*22D11G125A	Operating coil
1	-	-	-	-	-	-	-	-	-	-	-	-	-	-	1	-	-	-	-	-	*22D11G59A	Operating coil for Form W only
1	-	-	-	-	-	-	-	-	-	-	-	-	-	-	1	-	-	-	-	-	*22D11G262A	Operating coil for Form BW only
1	-	-	-	-	-	-	-	-	-	-	1	-	-	-	-	1	-	-	-	-	*22D11G70A	Operating coil
1	-	-	-	-	-	-	-	-	-	-	-	-	-	1	-	-	1	-	-	-	*22D11G55A	Operating coil
1	-	-	1	-	1	-	-	-	-	1	-	-	1	-	-	-	-	-	-	-	*22D11G44A	Operating coil
1	-	-	-	-	-	-	-	-	-	-	-	-	-	-	-	-	-	-	1	1	*22D11G124A	Operating coil
2	1	-	-	-	-	-	-	-	-	-	-	-	-	-	-	-	-	-	-	-	1445721	Retaining washer for operating coil
3	1	-	-	-	-	-	-	-	-	-	-	-	-	-	-	-	-	-	-	-	2810489G1	Magnet frame and core assembly
3	-	1	1	1	1	1	1	1	1	1	1	1	1	1	1	1	1	1	1	1	193A9125G1	Magnet frame and core assembly
4	1	1	1	1	1	1	1	1	1	1	1	1	1	1	1	1	1	1	1	1	N26P21012B6	Screw fastening magnet assembly to base (1/4-20, 3/4 in., hex hd. slot, pro fin)
5	1	1	1	1	1	1	1	1	1	1	1	1	1	1	1	1	1	1	1	1	219A1688P1	Armature
6	1	1	1	1	1	1	1	1	1	1	1	1	1	1	1	1	1	1	1	1	2453389	Guide strip for armature
7	1	-	-	-	-	-	-	-	-	-	-	-	-	-	-	-	-	-	-	-	576A123P1	Spring support for armature
7	-	1	1	1	1	1	1	1	1	1	1	1	1	1	1	1	1	1	1	1	576A123P2	Spring support for armature
8	2	2	2	2	2	2	2	2	2	2	2	2	2	2	2	2	2	2	2	2	N144P16010C	Screw with lock washer fastening guide strip and spring support to armature (10-32, 5/8 in., pan hd. pro fin)
9	†	-	-	-	-	-	-	-	-	-	-	-	-	-	-	-	-	-	-	-	167A9872P1	Spacer
9	-	†	†	†	†	†	†	†	†	†	†	†	†	†	†	†	†	†	†	†	167A9872P2	Spacer
10	2	-	-	-	-	-	-	-	-	-	-	-	-	-	-	-	-	-	-	-	N144P16008B6	Screw with lock washer fastening spacer to armature spring support (10-32, 1/2 in., pan hd. pro fin)
10	-	1	1	1	1	1	1	1	1	1	1	1	1	1	1	1	1	1	1	1	N144P16006B6	Screw with lock washer fastening spacer to armature spring support (10-32, 3/8 in., pan hd. pro fin)
11	1	1	1	1	1	1	1	1	1	1	1	1	1	1	1	1	1	1	1	1	177B8123P2	Stop plate for armature
12	4	4	4	4	4	4	4	4	4	4	4	4	4	4	4	4	4	4	4	4	N144P16010C	Screw with lock washer fastening stop plate to frame (10-32, 5/8 in., pan hd. pro fin)
	1	-	-	-	-	-	-	-	-	-	-	-	-	-	-	-	-	-	-	-	139B7147G3	Latch assembly for Forms A, C, D only
	1	-	-	-	-	-	-	-	-	-	-	-	-	-	-	-	-	-	-	-	139B7147G4	Latch assembly for Form B only
	-	1	1	1	1	-	-	1	-	1	-	-	1	-	-	-	-	-	1	1	139B7147G7	Latch assembly
	-	-	-	-	-	1	-	-	-	1	-	-	1	-	1	1	1	1	-	-	139B7147G9	Latch assembly
	-	-	-	-	-	-	1	-	1	-	-	-	-	-	-	-	-	-	-	-	139B7147G8	Latch assembly
13	1	1	1	1	1	1	1	1	1	1	1	1	1	1	1	1	1	1	1	1	N75P21022	Stop screw for armature (1/4-20, 1 3/8 in., hex hd. slot, brass)
14	1	1	1	1	1	1	1	1	1	1	1	1	1	1	1	1	1	1	1	1	167A5696P3	Space nut for stop screw
15	1	1	1	1	1	1	1	1	1	1	1	1	1	1	1	1	1	1	1	1	*53215P1	Compression spring for armature
16	1	1	1	1	1	1	1	1	1	1	1	1	1	1	1	1	1	1	1	1	125A4875P1	Guide pin for compression spring
17	1	1	1	1	1	1	1	1	1	1	1	1	1	1	1	1	1	1	1	1	578A552P2	Collar for guide pin
18	1	1	1	1	1	1	1	1	1	1	1	1	1	1	1	1	1	1	1	1	9196760P1	Lock nut for guide pin
19	1	1	1	1	1	1	1	1	1	1	1	1	1	1	1	1	1	1	1	1	161A7306P1	Retaining washer for compression spring
20	1	-	-	-	-	-	-	-	-	-	-	-	-	-	-	-	-	-	-	-	167A5695G1	Latch bar assembly
20	-	1	1	1	1	1	1	1	1	1	1	1	1	1	1	1	1	1	1	1	167A5695G2	Latch bar assembly
22	1	1	1	1	1	1	1	1	1	1	1	1	1	1	1	1	1	1	1	1	167A5696P1	Latch stop
23	1	1	1	1	1	1	1	1	1	1	1	1	1	1	1	1	1	1	1	1	167A5696P2	Shim for latch stop

* Parts recommended for normal stock.
 † Use as required to limit end play in latch assembly to 1/64 in. max with the armature pickup.

IC2820A102 AND CAT. NO. 228X275 RELAYS

Ref. No.	Number Required for 228X275G-										Catalog Number	Description	
	1	2	3	4	5	6	7	8	9	10			
1	1	-	1	-	-	1	-	1	-	-		*22D11G86	Operating coil
1	-	1	-	1	-	-	1	-	1	-		*22D11G55	Operating coil
1	-	-	-	-	1	-	-	-	-	1		*22D11G26	Operating coil
2	1	1	1	1	1	1	1	1	1	1		1445721	Retaining washer for operating coil
3	1	1	1	1	1	1	1	1	1	1		2810489G1	Magnet frame and core assembly
4	1	1	1	1	1	1	1	1	1	1		N26P21012B6	Screw fastening magnet assembly to base (1/4-20, 3/4 in., hex hd, slot, pro fin)
5	1	1	1	1	1	1	1	1	1	1		9098152P1	Armature
6	1	1	1	1	1	1	1	1	1	1		2453389P1	Guide strip for armature
7	1	1	1	1	1	1	1	1	1	1		576A123P1	Spring support for armature
8	2	2	2	2	2	2	2	2	2	2		N144P16010C	Screw with lock washer fastening guide strip and spring support to armature (10-32, 5/8 in., pan hd, pro fin)
9	4	4	4	4	4	4	4	4	4	4		167A9872P1	Spacer
10	2	2	2	2	2	2	2	2	2	2		N144P16008B6	Screw with lock washer fastening spacer to armature spring support (10-32, 1/2 in., pan hd, pro fin)
11	1	1	1	1	1	1	1	1	1	1		9034493P2	Stop plate for armature
12	2	2	2	2	2	2	2	2	2	2		N144P16010C	Screw with lock washer fastening stop plate to frame (10-32, 5/8 in., pan hd, pro fin)
	1	1	1	1	1	1	1	1	1	-		139B7147G5	Latch assembly
	-	-	-	-	-	-	-	-	-	1		139B7147G6	Latch assembly
15	1	1	1	1	1	1	1	1	1	1		*53215P1	Compression spring for armature
16	1	1	1	1	1	1	1	1	1	1		125A4875P1	Guide pin for compression spring
17	1	1	1	1	1	1	1	1	1	1		578A552P2	Collar for guide pin
18	1	1	1	1	1	1	1	1	1	1		9196760P1	Lock nut for guide pin
19	1	1	1	1	1	1	1	1	1	1		161A7306P1	Retaining washer for compression spring
20	1	1	1	1	1	1	1	1	1	1		167A5695G1	Latch bar assembly
22	1	1	1	1	1	1	1	1	1	1		167A5696P1	Latch stop
23	1	1	1	1	1	1	1	1	1	1		167A5696P2	Shim for latch stop
24	1	1	1	1	1	1	1	1	1	1		N57P15008B6	Screw fastening latch bar, latch stop, and shim to armature stop plate (8-32, 1/2 in., pan hd, slot, pro fin)
25	1	1	1	1	1	1	1	1	1	1		*574A743P1	Tension spring for latch bar assembly
26	1	1	1	1	1	1	1	1	1	1		576A118P1	Operating arm for interlock
27	1	1	1	1	1	1	1	1	1	1		2450533P1	Shim for operating arm
28	2	2	2	2	2	2	2	2	2	2		N75P15006	Screw fastening interlock operating arm and shim to armature (8-32, 3/8 in., pan hd, slot, brass)
29	1	1	-	-	-	1	1	-	-	-		IC2956A200AS	Switch unit
29	-	-	1	1	-	-	-	1	1	-		IC2956A200AU	Switch unit
29	-	-	-	-	1	-	-	-	-	1		IC2956A200BB	Switch unit
	1	1	1	1	1	1	1	1	1	1		*6960053G3	Set of interlock contacts, with springs and contact-holding screws
30	1	1	1	1	-	1	1	1	1	-		*129B5782G1	Rectifier board assembly
30	-	-	-	-	1	-	-	-	-	1		*129B5782G3	Rectifier board assembly
31	1	1	1	1	1	1	1	1	1	1		N57P15006B6	Screw fastening rectifier board assembly to interlock mounting bracket (8-32, 3/8 in., pan hd, slot, pro fin)
32	1	-	1	-	-	1	-	1	-	-		168A1796G1	Resistor
33	1	-	1	-	-	1	-	1	-	-		N57P13004B6	Screw for resistor terminal (6-32, 1/4 in., pan hd, slot, pro fin)
34	1	-	1	-	-	1	-	1	-	-		167A9933P1	Support for resistor
35	2	-	2	-	-	2	-	2	-	-		N144P15006B6	Screw with lock washer fastening support to base (8-32, 3/8 in., pan hd, pro fin)
36	1	1	1	1	1	1	1	1	1	1		167A5694P1	Base

* Parts recommended for normal stock

GENERAL ELECTRIC COMPANY
INDUSTRIAL CONTROL DEPARTMENT
SALEM, VA. 24153

