

RENEWAL PARTS

IC2820-C100 RELAYS

Forms A, B, C, and D

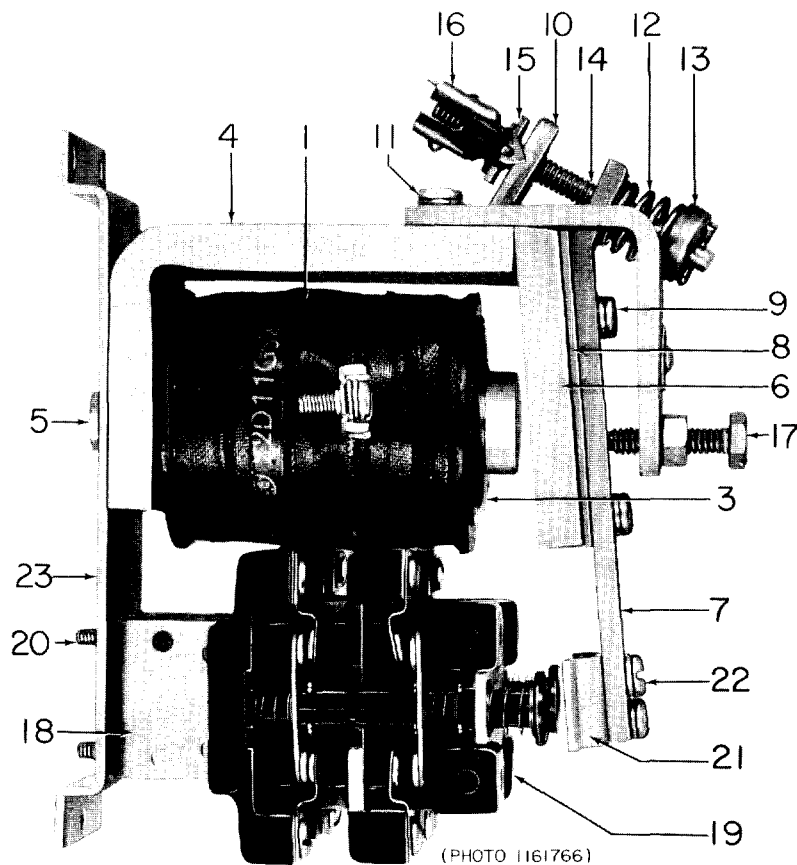

IC2820-C100B relay

NOTE:—When ordering parts for a form of the relay not covered by this bulletin, give reference number, description of part, complete nameplate reading, and above bulletin (GEF) number. *Do not use catalog number when form for which the parts are needed is not covered by the bulletin.*

When ordering renewal parts, give quantity, catalog number, description of each item required, and complete nameplate reading.

GENERAL  ELECTRIC

IC2820-C100 RELAYS

PARTS RECOMMENDED FOR NORMAL STOCK

Ref. No.	Number Required for IC2820-C100-				Catalog Number	Description
	A	B	C	D		
1	1	1	1	1	- - -	Operating coil (see table below)
	1	1	1	2	6960053G3	Set of movable and stationary contacts with springs and contact-holding screws (For switch unit Cat. IC2956A200A, IC2956A200B and IC2956A200C)
	1	1	-	-	6960053G2	Set of movable and stationary contacts with springs and contact-holding screws (For switch unit Cat. IC2956A200H)
12	1	1	1	1	235184	Compression spring for armature

Ref. No. 1 - OPERATING COILS - 1 Required

NOTE:- The operating coil is identified by the number following the form letter in the IC designation.

EXAMPLE:- IC2820-C100-A-2-B requires operating coil No. 2, Cat. No. 3245059.

Coil No.	Catalog Number	Coil No.	Catalog Number	Coil No.	Catalog Number	Coil No.	Catalog Number	Coil No.	Catalog Number
FORMS A AND B									
2	§3245059	6	§3247657	10	‡22D13G7	14	‡22D13G8	18	‡22D13G5
3	§3245060	7	§3248602	11	‡22D13G13	15	‡22D13G5	19	‡22D13G82
4	§3246873	8	§3248626	12	‡22D13G3	16	‡22D13G63	20	§3323120
5	§3246884	9	§3323101	13	‡22D13G42	17	‡22D13G42		

FORMS C AND D									
1	22D11G43	11	‡22D13G31	21	22D11G168	31	22D11G54	41	22D11G61
2	22D11G44	12	‡22D13G32	22	‡22D13G7	32	3021124	42	‡2693247P15
3	22D11G45	13	‡22D13G5	23	22D11G77	33	22D11G96		3028137
4	22D11G46	14	‡22D13G38	24	22D11G136	34	22D11G100	43	‡2693247P34
5	22D11G26	15	‡22D13G3	25	‡22D13G8	35	22D11G74		3241257
6	22D11G47	16	‡22D13G82	26	‡22D13G39	36	‡3241953	44	‡2693247P1
7	22D11G25	17	‡22D13G4	27	‡22D13G69	37	22D11G170	45	22D11G9
8	22D11G48	18	‡22D13G7	28	‡22D13G63	38	3241960	46	22D11G75
9	22D11G49	19	‡22D13G2	29	22D11G69	39	22D11G29	47	22D125G3
10	22D11G50	20	‡22D13G13	30	22D11G55	40	22D11G86		

§ Requires copper jacket, Cat. No. 9092010.

‡ Requires copper jacket, Cat. No. 2494629.

‡ Edgewise wound copper.

COMPLETE LIST OF PARTS

Ref. No.	Number Required for IC2820-C100-				Catalog Number	Description
	A	B	C	D		
3	1	1	1	1	1445721	Retaining washer for operating coil
4	1	1	1	1	9397583G1	Magnet frame with core
5	1	1	1	1	N26P21012B	Screw fastening magnet core to base (1/4 in. -20, 3/4 in. hex. hd. slot, pro. fin.)
	Δ	Δ	-	Δ	8626009P13	Lock washer between coil and magnet frame (To be used when copper jacket, Cat. No. 9092010 is furnished)
	Δ	Δ	Δ	Δ	8626009P12	Lock washer between coil and magnet frame (To be used when copper jacket, Cat. No. 2494629 is furnished)
6	1	1	1	1	9098152	Armature
	1	1	1	1	9644941	Adjustable shim for armature
	1	1	1	1	9098151	Stationary shim for armature
	1	1	1	1	8058795	Clamp for shims

Δ Quantity variable.

COMPLETE LIST OF PARTS (cont'd)

Ref. No.	Number Required for IC2820-C100-				Catalog Number	Description
	A	B	C	D		
	2	2	2	2	N75P15010	Screw fastening shims and clamp to armature (8-32, 5/8 in. pan hd., brass)
7	1	1	-	1	576A123P1	Support for armature
7	-	-	1	-	1459971	Support for armature
8	1	1	1	1	2453389	Guide strip between armature and support
9	2	2	2	2	N144P16010C	Screw with lock washer fastening support and guide strip to armature
10	1	1	1	1	9034493P1	Bracket for armature
11	2	2	2	2	N144P16010C	Screw with lock washer fastening bracket to magnet frame
12	1	1	1	1	235184	Compression spring for armature
13	1	1	1	1	437972P1	Spring seat for compression spring
14	1	1	1	1	125A4875P1	Adjusting screw for compression spring
15	1	1	1	1	6955638	Support for adjusting screw
16	1	1	1	1	9196760P1	Lock nut for adjusting screw
17	1	1	1	1	N26P21016B	Stop screw for armature (1/4 in. -20, 1 in. hex. hd. slot, pro. fin.)
18	1	1	-	1	723B245G7	Switch unit with mounting bracket (2 normally open contacts)
18	1	-	-	-	723B245G28	Switch unit with mounting bracket (1 normally closed contact)
18	-	1	-	-	723B245G27	Switch unit with mounting bracket (1 normally closed contact)
18	-	-	1	-	723B245G26	Switch unit with mounting bracket (1 normally open and 1 normally closed contact)
18	-	-	-	1	723B245G8	Switch unit with mounting bracket (2 normally closed contacts)
19	1	1	-	1	IC2956A200A	Switch unit only (2 normally open contacts)
19	1	1	-	-	IC2956A200H	Switch unit only (1 normally closed contact)
19	-	-	1	-	IC2956A200C	Switch unit only (1 normally open and 1 normally closed contact)
19	-	-	-	1	IC2956A200B	Switch unit only (2 normally closed contacts)
	1	1	1	2	6960053G3	Set of movable and stationary contacts with springs and contact-holding screws (For switch unit Cat. No. IC2956A200A, IC2956A200B, and IC2956A200C)
	1	1	-	-	6960053G2	Set of movable and stationary contacts with springs and contact-holding screws (For switch unit Cat. No. IC2956A200H)
20	4	4	2	4	576A145P4	Screw fastening switch unit to base
21	1	1	-	1	576A117P1	Operating arm for switch unit
	-	-	1	-	576A118P1	Operating arm for switch unit
22	2	2	-	2	N144P16008C	Screw with lock washer fastening operating arm to armature support
	-	-	2	-	N75P15006	Screw fastening operating arm to armature (8-32, 3/8 in. pan hd., brass)
23	1	1	-	1	576A112P1	Base for relay
23	-	-	1	-	576A113P1	Base for relay

**GENERAL ELECTRIC COMPANY
INDUSTRIAL CONTROL PRODUCTS DEPARTMENT
SALEM, VA. 24153**

GENERAL  ELECTRIC