



PB-31101-031A
Supersedes PB-31101-031

GE Renewal Parts

Use original equipment parts for reliability

PARTS BULLETIN

**DRILLING MOTOR
MODEL 5GE752ARB2A**

NOVEMBER 4, 1992

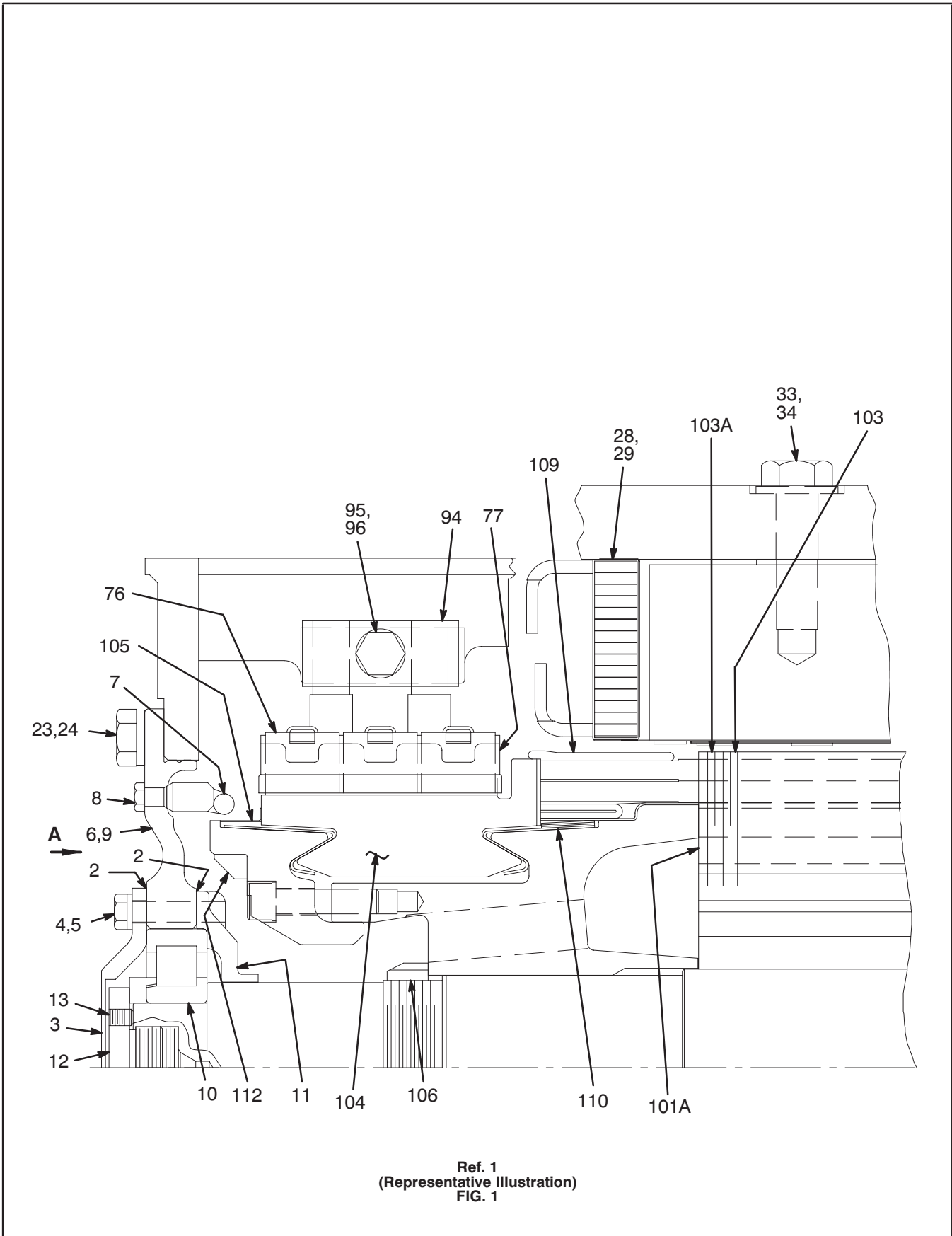

Ref. 1
(Representative Illustration)
FIG. 1

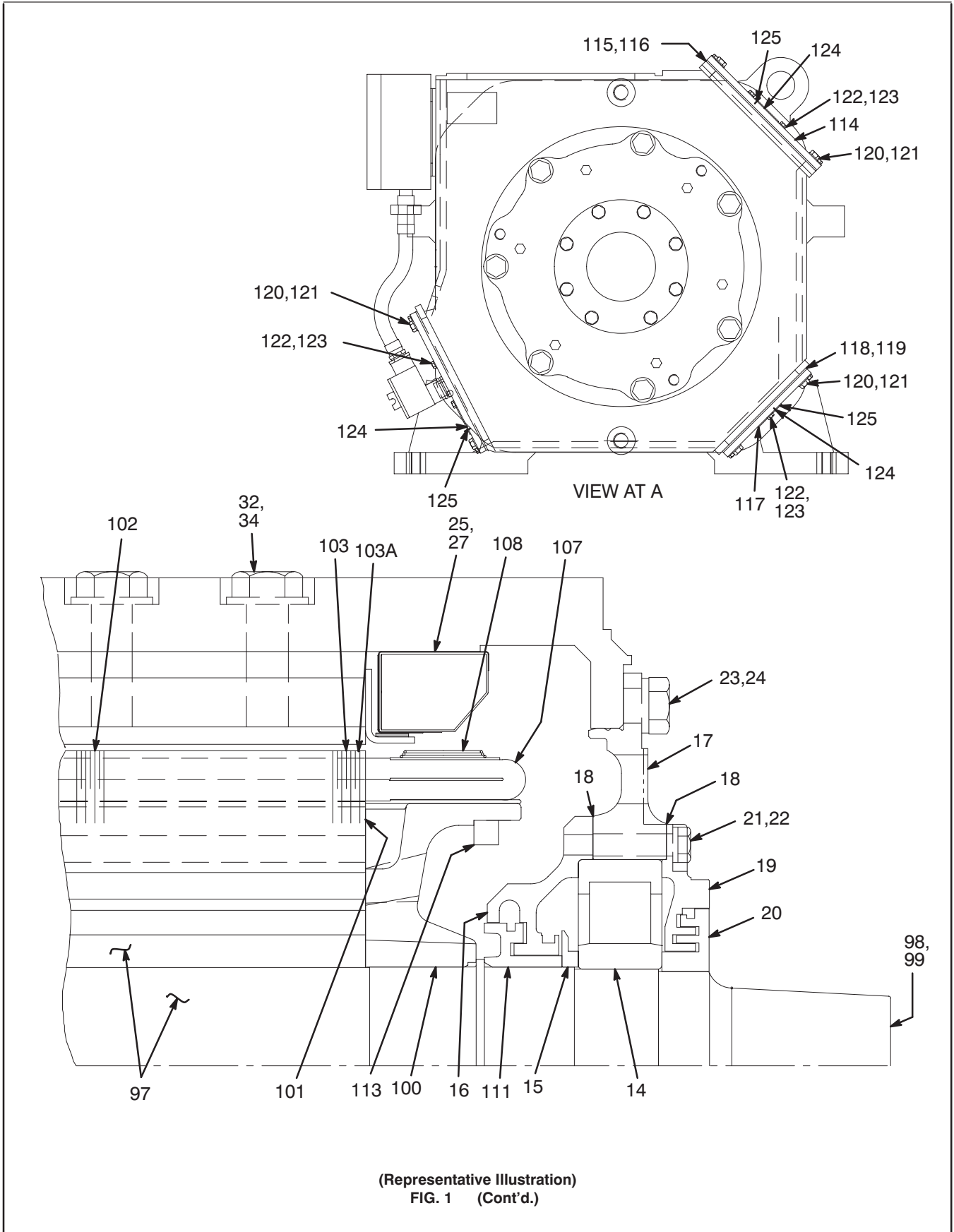

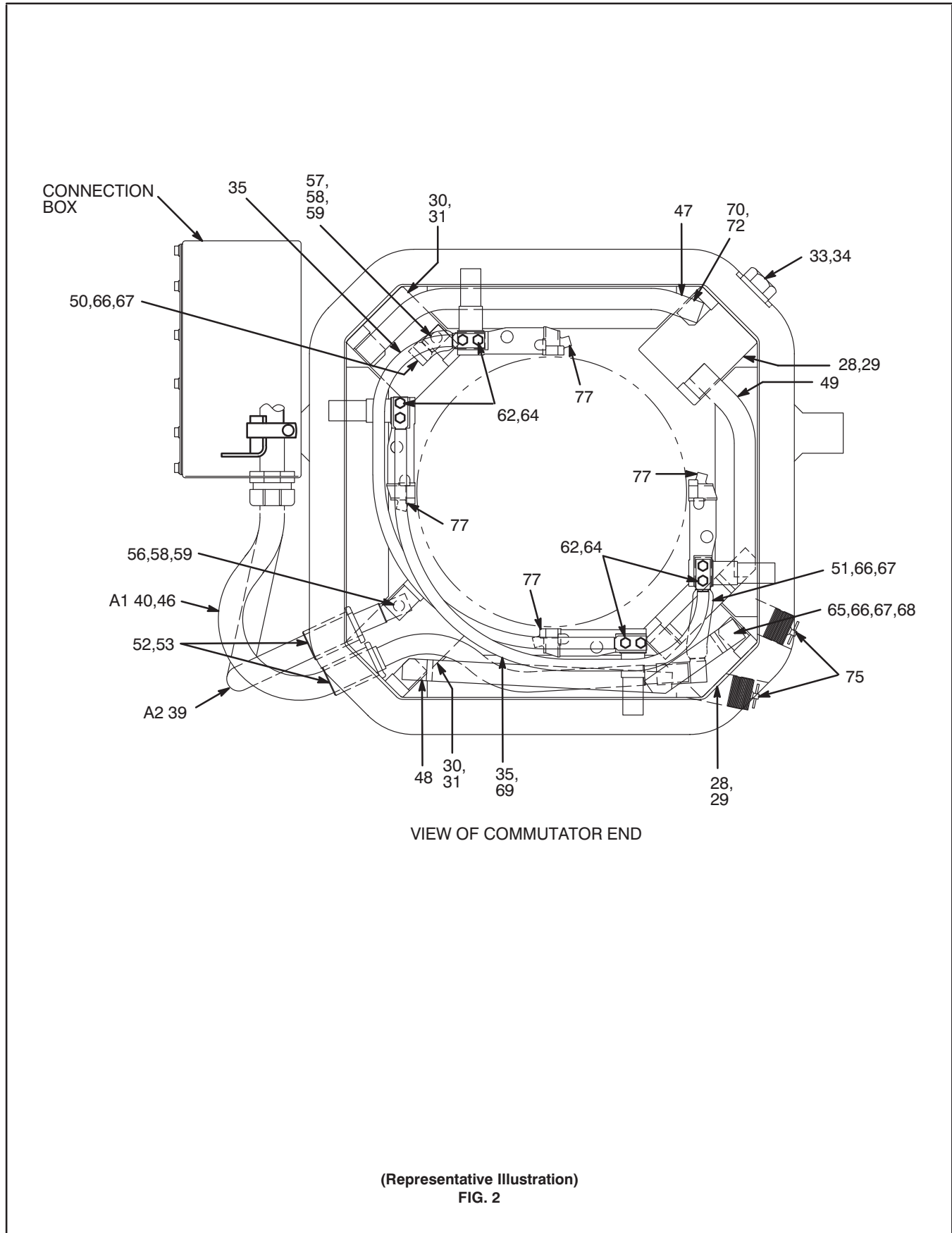

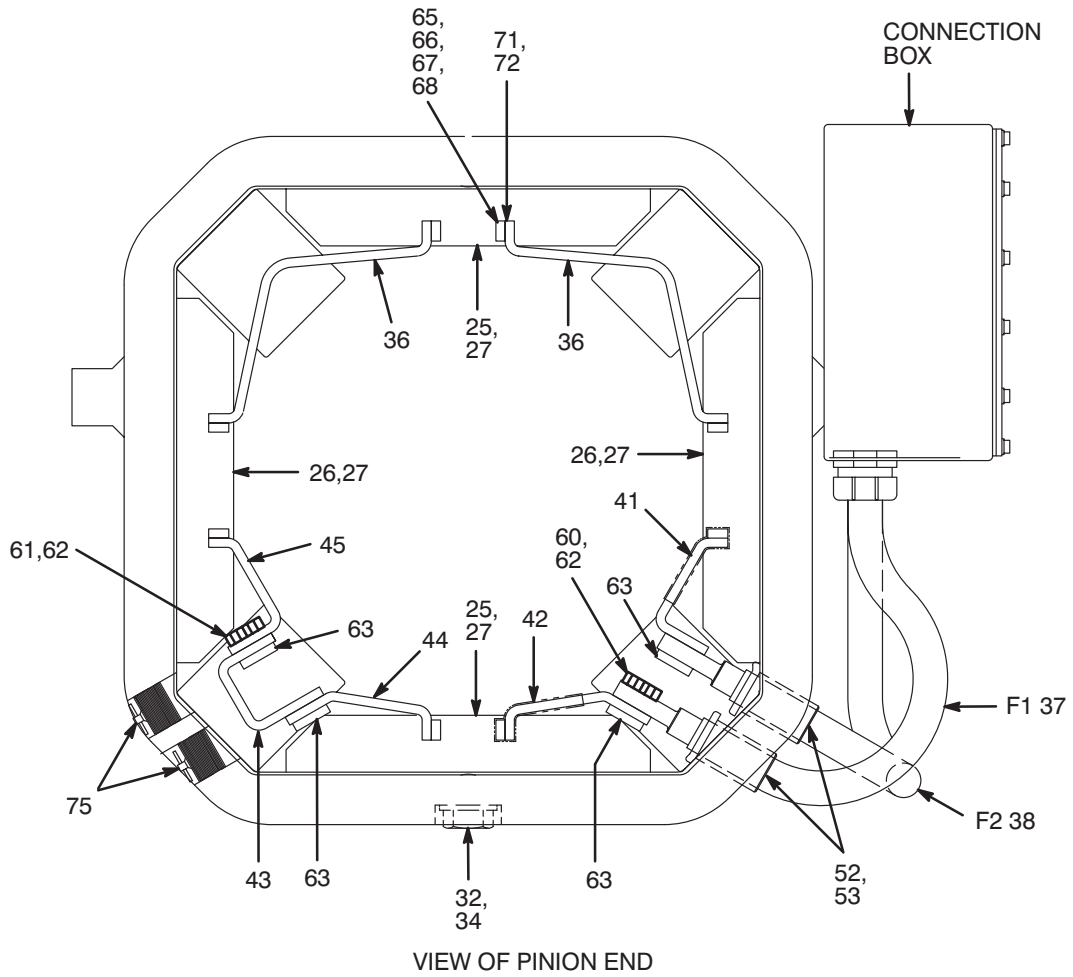

(Representative Illustration)
FIG. 2 (Cont'd.)

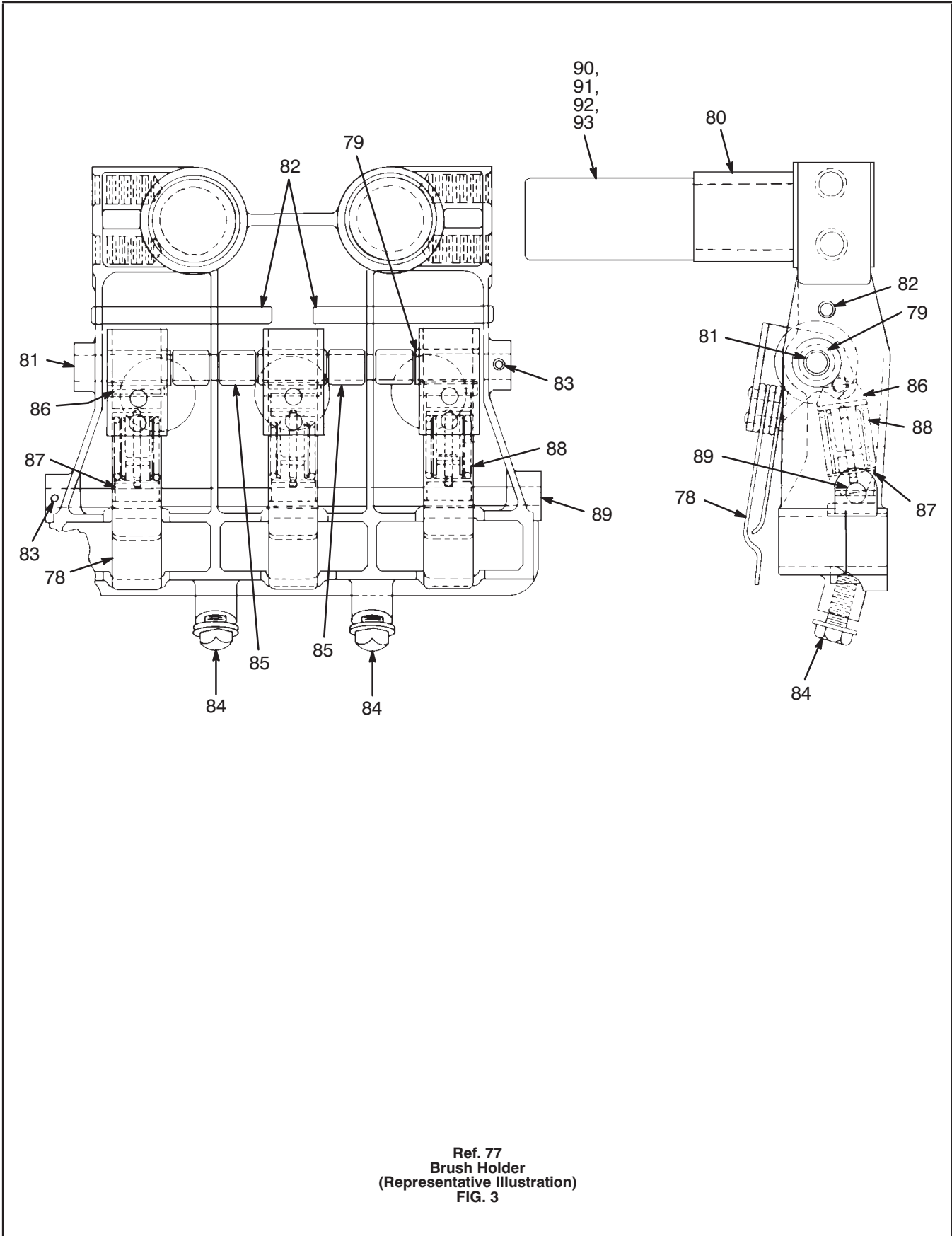

Ref. 77
Brush Holder
(Representative Illustration)
FIG. 3

FIG. NO.	REF. NO.	PART NO.	QUANT REQ. COL. A	DESCRIPTION
1	1	5GE752ARB2A	1	DRILLING MOTOR
1	2	4732368P1	2	+GASKET, 0.021 IN THK
1	3	6739891P1	1	BEARING CAP
1	4	N22P33048	8	BOLT, HEX HD, 5/8 IN-11, 3 IN LONG
1	5	41B537660P9	8	WASHER, FLAT, 0.725 IN ID, 1 IN OD
1	6	9949565G1	1	FRAME HEAD ASSEMBLY
1	7	481A560G1	1	FLASH RING
1	8	N22P29020B13	6	BOLT, HEX HD, 1/2 IN-13, 1 1/4 IN LONG
1	9	N509P2516	1	PIN, SPRING DOWEL, 1/4 IN DIA, 1 IN LONG
1	10	8864951P119	1	+ROLLER BEARING
1	11	334B761P1	1	BEARING CAP
1	12	949X47	1	RETAINING NUT WITH SET SCREW
1	13	41A239107P1	2	SCREW, HEX SOC HD, 1/2 IN-13, 3/4 IN LONG
1	14	8864951P167	1	+ROLLER BEARING
1	15	4713640P1	1	FLINGER
1	16	6744700P2	1	BEARING CAP, INNER
1	17	41C637314P1	1	FRAME HEAD
1	18	4732906P1	2	+GASKET, 0.021 IN THICK
1	19	2739317P1	1	BEARING CAP
1	20	4732351P1	1	SLEEVE
1	21	N22P33056	8	BOLT, HEX HD, 5/8 IN-11, 3 1/2 IN LONG
1	22	41B537660P9	8	WASHER, FLAT, 0.725 IN ID, 1 IN OD
1	23	N22P39032	11	BOLT, HEX HD, 1 IN-8, 2 IN LONG
1	24	41B537660P21	11	WASHER, FLAT, 1.063 IN ID, 2 IN OD
1,2	25	41E903691G7	2	*EXCITING COIL
2	26	41E903691G8	2	*EXCITING COIL
1,2	27	41B537112G2	4	POLE PIECE, EXCITING COIL
1,2	28	41C637285G7	2	COIL WITH POLE PIECE, COMMUTATING
1,2	29	41C637285G8	2	COIL, COMMUTATING
2	30	41C637285G10	2	*COIL WITH POLE PIECE, COMMUTATING
2	31	41C637285G11	2	*COIL, COMMUTATING
1,2	32	N22P45060	12	BOLT, HEX HD, 1 1/4 IN-7, 3 3/4 IN LONG
1,2	33	41A239559P1	12	BOLT, HEX HD, 1 1/4 IN-12, 4 IN LONG
1,2	34	41B537660P22	24	WASHER, FLAT, 1.453 IN ID, 2.500 IN OD
2	35	41C636243G2	2	CABLE ASSEMBLY
2	36	41C636867G3	2	#CONNECTION STRAP
2	37	41C637268G1	1	CABLE ASSEMBLY
2	38	41C637268G2	1	CABLE ASSEMBLY
2	39	41D735504G3	1	CABLE ASSEMBLY
2	40	41D735504G5	1	CABLE ASSEMBLY

* ADDED OR CHANGED SINCE LAST ISSUE.

WELD OR BRAZE IN POSITION.

+ RECOMMEND CUSTOMER STOCK THIS PART.

FIG. NO.	REF. NO.	PART NO.	QUANT REQ. COL. A	DESCRIPTION
2	41	41C637269G2	1	#CONNECTION STRAP
2	42	41C637269G1	1	#CONNECTION STRAP
2	43	41C637269P1	1	CONNECTION STRAP
2	44	41C637269G3	1	CONNECTION STRAP
2	45	41C637269G4	1	CONNECTION STRAP
		DELETED	8	NOT USED
2	47	41C637261G1	1	CONNECTION STRAP, INSULATED
2	48	41C637261G5	1	CONNECTION STRAP, INSULATED
2	49	41C637261G2	1	CONNECTION STRAP, INSULATED
2	50	41D735504G7	1	SHUNT ASSEMBLY
2	51	41D735504G6	1	SHUNT ASSEMBLY
2	52	481A539P20	4	CABLE BUSHING, 1 1/2 IN ID, RUBBER
2	53	41A216775P1	AR	+SEALANT, 1/8 BY 3 3/4 IN, 10 FT ROLL
		DELETED	2	NOT USED
		DELETED	2	NOT USED
2	56	N22P33028	1	BOLT, HEX HD, 5/8 IN-11, 1 3/4 IN LONG
2	57	N22P33024	1	BOLT, HEX HD, 5/8 IN-11, 1 1/2 IN LONG
2	58	N405P47B13	2	LOCKWASHER, 5/8 IN
2	59	N213P33	2	NUT, HEX, JAM, 5/8 IN-11
2	60	N22P27028B13	6	BOLT, HEX HD, 7/16 IN-14, 1 3/4 IN LONG
2	61	N22P27024B13	4	BOLT, HEX HD, 7/16 IN-14, 1 1/2 IN LONG
2	62	N405P44B13	20	LOCKWASHER, 7/16 IN
2	63	4713845P1	3	*BOLTING PLATE
2	64	N22P27020B13	10	BOLT, HEX HD, 7/16 IN-14, 1 1/4 IN LONG
2	65	41A239176P443	AR	SILASTIC PUTTY
2	66	41A239176P133	AR	SILICONE TAPE, 0.015 IN THICK, 1 IN WIDE
2	67	41A239176P22	AR	GLASS TAPE, 0.007 IN THICK, 1 IN WIDE
2	68	41A239176P487	AR	VARNISH
2	69	41A239176P399	AR	CORD
2	70	41A231281P47	7	BRAZING STRIP
2	71	41A231281P46	8	BRAZING STRIP, 1 IN X 1 IN LONG
2	72	41A330300P2	AR	BRAZING ALLOY, 0.050 X 0.062 IN
		DELETED	4	NOT USED
		DELETED	4	NOT USED
2	75	41A239663P2	4	PLUG
1	76	41B537963P1	12	*CARBON BRUSH
1,2,3	77	41C632667G6	4	+BRUSH HOLDER ASSEMBLY
3	78	41B530659G2	12	PRESSURE ARM
3	79	41A231370P2	12	BUSHING, 1.063 IN LONG
3	80	186V831P1	8	SLEEVE

* ADDED OR CHANGED SINCE LAST ISSUE.
WELD OR BRAZE IN POSITION.
+ RECOMMEND CUSTOMER STOCK THIS PART.

FIG. NO.	REF. NO.	PART NO.	QUANT REQ. COL. A	DESCRIPTION
3	81	41A231378P2	4	PIN, 3/8 IN DIA, 6 5/8 IN LONG
3	82	N509P2548	8	PIN, SPRING DOWEL, 1/4 IN DIA, 3 IN LONG
3	83	N509P912	8	PIN, SPRING DOWEL, 3/32 IN DIA, 3/4 IN LONG
3	84	41A230733P7	8	BOLT W/WASHER, HEX HD SL, 5/16 IN-18, 3/4 IN LONG
3	85	41A231370P6	16	BUSHING, 0.575 IN LONG
3	86	41A330248P1	12	SPRING SEAT
3	87	41A233867G4	12	SPRING SEAT WITH PIN
3	88	41B537844G1	12	SPRING SET ASSEMBLY
3	89	41A233880P1	4	PIN, 7 7/16 IN LONG
3	90	41B535754G28	8	BRUSH HOLDER STUD, MOLDED (0.002 IN OVERSIZE)
3	91	41B535754G29	8	BRUSH HOLDER STUD, MOLDED (0.004 IN OVERSIZE)
3	92	41B535754G30	8	BRUSH HOLDER STUD, MOLDED (0.006 IN OVERSIZE)
3	93	41B535754G31	8	BRUSH HOLDER STUD, MOLDED (0.008 IN OVERSIZE)
1	94	2733755P7	4	SUPPORT, BRUSH HOLDER
1	95	N22P37052	4	BOLT, HEX HD, 7/8 IN-9, 3 1/4 IN LONG
1	96	41B537660P25	4	WASHER, FLAT, 0.968 IN ID, 1.375 IN OD
1	97	41D735773G1	1	*ARMATURE ASSEMBLY
1	98	41C636928G1	1	SHAFT WITH PLUG
1	99	8819420P1	2	PLUG, HEX SOC HD, 3/8 IN-24, 1 IN LONG
1	100	41B537605P4	1	*ARMATURE HEAD
1	101	41A239323G1	1	*PUNCHING, END
1	101A	41A330418G1	1	PUNCHING, END
1	102	41B537164P1	553	PUNCHING, MAIN
1	103	41B537165P1	26	*PUNCHING, STEP BACK
1	103A	41B537165P2	14	PUNCHING, STEP BACK
1	104	41B537889G2	1	COMMUTATOR, SEASONED
1	105	41B537080P1	1	=TEFLON BAND (CONTINUOUS)
1	106	189V584P1	1	NUT
1	107	41D735370G5	1	*ARMATURE REWIND KIT
1	108	41A330208P10	AR	WIRE, 0.072 IN DIA
1	109	41A239176P64	AR	GLASS TAPE, 0.014 IN THICK, 3/4 IN WIDE
1	110	41A239176P62	AR	GLASS TAPE, 0.014 IN THICK, 3/8 IN WIDE
1	111	41A232821P1	1	SLEEVE
1	112	2766829ADP24	AR	#BALANCE WEIGHT, 13 IN OD
1	113	2766829ADP26	AR	#BALANCE WEIGHT, 14 3/4 IN OD
1	114	41B537853G2	1	INSPECTION COVER, 9.50 IN X 12.50 IN LONG
1	115	41B537853P4	1	+GASKET, 9.50 X 12.50 X 0.125 IN THK
1	116	497A806P12	AR	+CEMENT
1	117	41B537853G1	1	COVER, INSPECTION, 9.50 IN X 9.50 IN SQ

* ADDED OR CHANGED SINCE LAST ISSUE.

WELD OR BRAZE IN POSITION.

+ RECOMMEND CUSTOMER STOCK THIS PART.

= ADDITIONAL MATERIAL IS REQUIRED TO INSTALL THE CONTINUOUS LOOP TEFLON BAND. SEE APPLICATION INSTRUCTIONS, GEK-76278.

FIG. NO.	REF. NO.	PART NO.	QUANT REQ. COL. A	DESCRIPTION
1	118	41B537853P2	1	+GASKET, 9.50 X 9.50 X 0.125 IN THK
1	119	497A806P12	AR	+CEMENT
1	120	N14P29020B13	8	*BOLT, HEX HD, 1/2 IN-13, 1 1/4 IN LONG
1	121	41B537660P6	8	*WASHER, FLAT, 0.562 IN ID, 0.938 IN OD
1	122	N22P23020B13	10	*BOLT, HEX HD, 5/16 IN-18, 1 1/4 IN LONG
1	123	41A231459P1	10	*WASHER, FLAT, 0.344 IN ID
1	124	41A237902P1	3	PLATE (WARNING - DO NOT OPEN WHILE -)
1	125	N532P1104	12	ESCUTCHEON PIN, NO 12, 1/4 IN LONG

* ADDED OR CHANGED SINCE LAST ISSUE.
+ RECOMMEND CUSTOMER STOCK THIS PART.

- END OF PARTS BULLETIN -