



## GE Renewal Parts

---

Use original equipment parts for reliability

PARTS BULLETIN

UNCONTROLLED COPY

See On-Line Master for Current Revision

---

**DRILL MOTOR MODEL 5GEB29B1**

05-AUG-2020

---

---

**© 2020 General Electric Company. All rights reserved. The information contained in this publication is the property of General Electric Company and is disclosed in confidence. This publication is intended for use by GE customers solely for purposes of operating and conducting normal running maintenance of purchased or licensed GE products, and it shall not be reproduced, redistributed, retransmitted, translated, abridged, adapted, condensed, revised or otherwise modified, in any form, in whole or in part, or used for any other purpose, without the express written consent of GE. However, if a GE customer (“Customer”) requires additional copies of this document or portions thereof for internal use, GE hereby grants to Customer a limited right to reproduce this publication, in whole or in part, and Customer agrees to use such authorized copies (“Copies”) solely for its intended purposes. Any Copies made under this limited reproduction right shall contain this notice and any other legal notices appearing in this publication. The Customer shall be responsible for complying with U.S. export control laws with respect to distribution of all Copies.**

**GE and Customer agree that the information contained herein does not purport to cover all details or variations in GE products or to provide for every possible contingency with installation, operation or maintenance. Should further information be desired or should particular problems arise that are not covered sufficiently for the user’s purposes, the matter should be referred to General Electric Company. Any applicable Federal, State or local regulations or company safety or operating rules must take precedence over any information or instructions given in the Technical Documentation. GE has no obligation to keep the material up to date after the original publication.**

**GENERAL ELECTRIC COMPANY EXPLICITLY DISCLAIMS ALL WARRANTIES OF ACCURACY, MERCHANTABILITY OR FITNESS FOR ANY PURPOSE IN CONNECTION WITH THE TECHNICAL DOCUMENTATION AND USE THEREOF.**

---

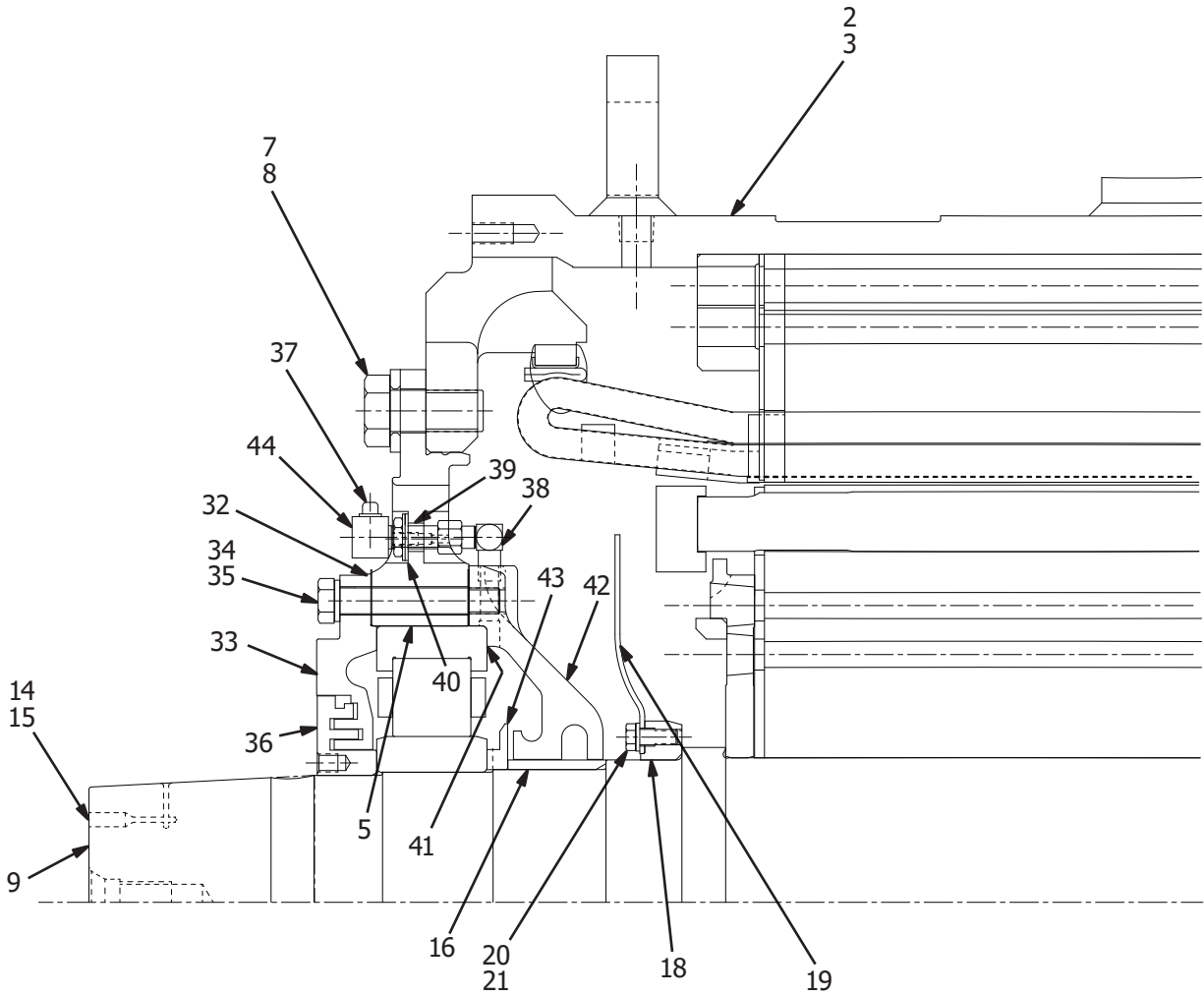

Ref. 1  
(Representative Illustration)  
FIG. 1

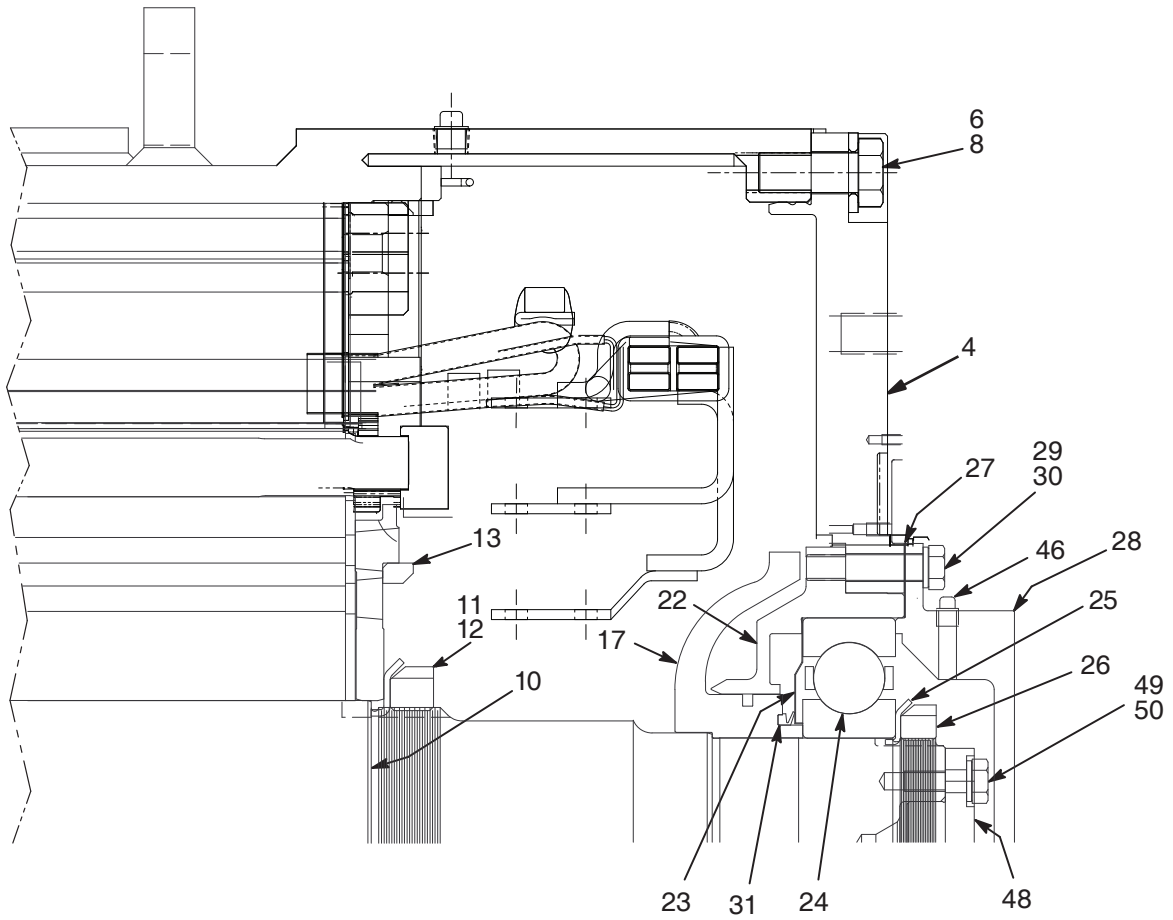

(Representative Illustration)  
FIG. 1 (Cont'd)

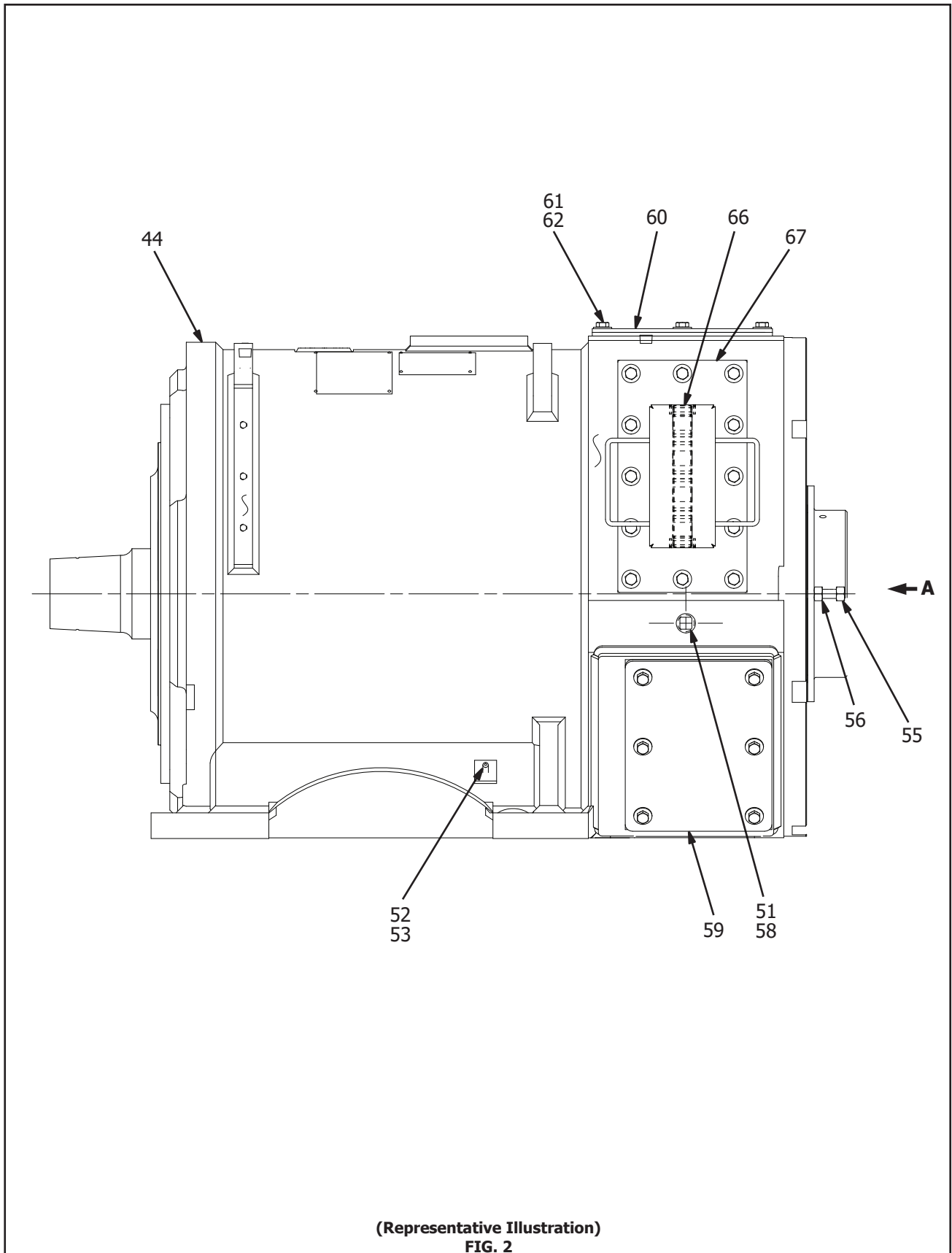

(Representative Illustration)  
FIG. 2

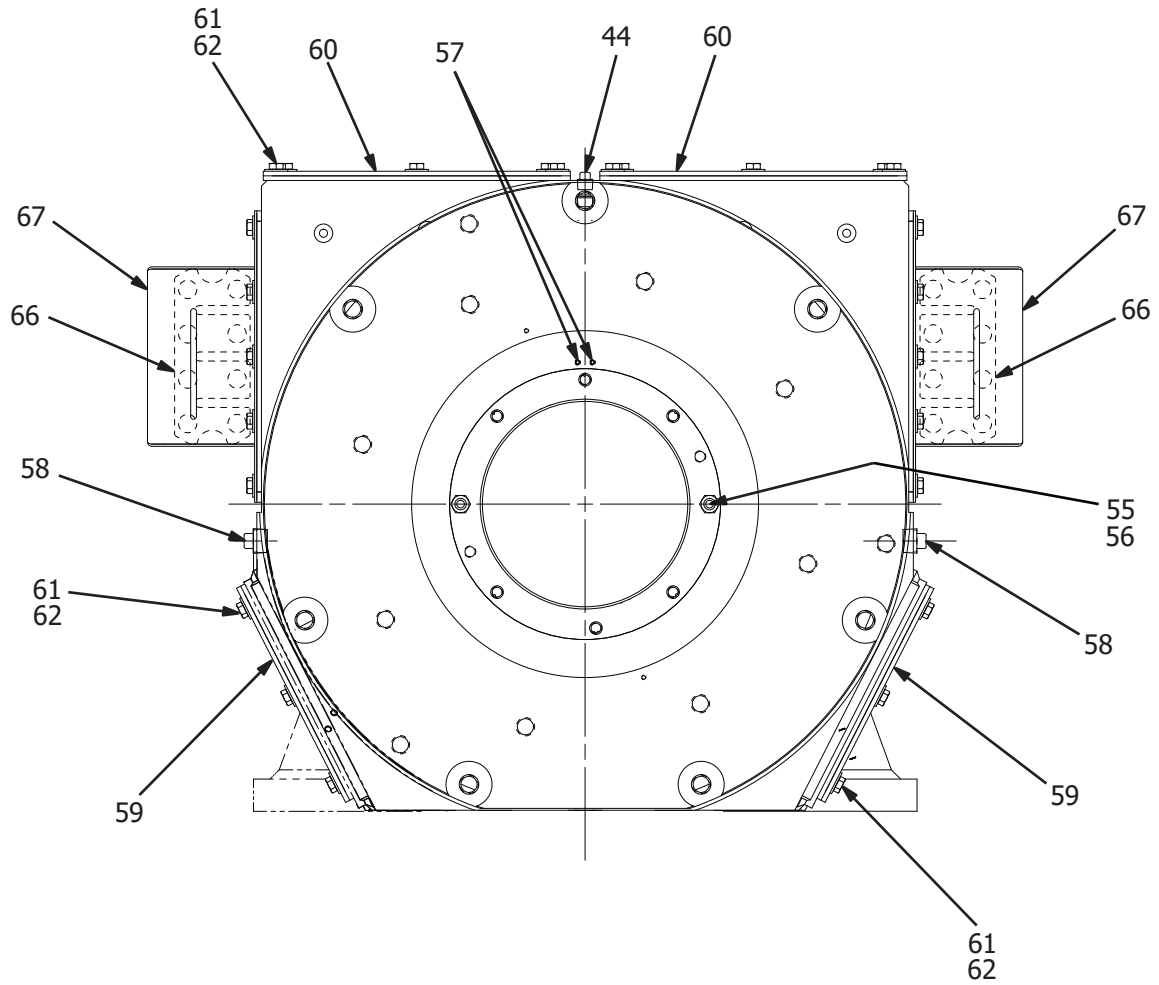

VIEW A

(Representative Illustration)  
FIG. 2 (Cont'd)

GE Proprietary and Confidential Information  
UNCONTROLLED COPY

PB-31114-002

DRILL MOTOR MODEL 5GEB29B1  
See On-Line Master for Current Revision

---

FIG. NO.	REF. NO.	PART NO.	QTY	DESCRIPTION
1	1	5GEB29B1	1	AC MOTOR (SEE PB-31114-002)
1	2	84E901397G6	1	STATOR ASSEMBLY
1	3	84E901397G7	1	STATOR REWIND KIT
1	4	84D730299P1	1	FRAMEHEAD, COMMUTATOR END
1	5	84C603506P2	1	FRAMEHEAD, PINION END
1	6	N14P39040	7	BOLT, 1 IN-8, 2 1/2 IN LONG
1	7	N14P39036	8	BOLT, 1 IN-8, 2 1/4 IN LONG
1	8	41B537660P20	15	WASHER, FLAT, 1.063 IN ID, 2 IN OD
1	9	84C603619G6	1	ROTOR ASSEMBLY
1	10	84D730382P2	1	ROTOR SHAFT
1	11	8864959P134	1	LOCKWASHER, ROTOR SHAFT
1	12	8864959P200	1	LOCK NUT, ROTOR SHAFT
1	13	2766829ADP43	AR	BALANCE WEIGHT, 3/4 IN WIDE
1	14	84A204808P1	1	SET SCREW, OVAL POINT, 0.375 IN-24
1	15	3X8717	AR	ADHESIVE PUTTY, 8 OZ CAN W/BRUSH APPLICATOR
1	16	84B517381P1	1	COLLAR
1	17	41B539181P2	1	GEAR, SPEED SENSOR
1	18	84B517382P1	1	RING
1	19	84B517399P1	1	BAFFLE
1	20	N22P25016B13	8	BOLT, HEX HD, 3/8 IN-16, 1 IN LONG
1	21	41B537660P1	8	WASHER, FLAT, 0.435 IN ID, 0.675 IN OD, .090 IN THICK
1	22	41C637267P2	1	BEARING HOUSING
1	23	84A216663P1	1	SEAL RING, NILOS
1	24	8864950P364	1	BEARING, 130 MM
1	25	8864959P126	1	LOCKWASHER
1	26	8864959P26	1	LOCKNUT
1	27	493A546P1	1	GASKET, 14 11/16 IN OD

GE Proprietary and Confidential Information  
UNCONTROLLED COPY

PB-31114-002

**DRILL MOTOR MODEL 5GEB29B1**  
See On-Line Master for Current Revision

FIG. NO.	REF. NO.	PART NO.	QTY	DESCRIPTION
1	28	84C603611P1	1	BEARING CAP
1	29	41B537660P9	8	WASHER, FLAT, 0.725 IN ID, 1 IN OD, 0.125 IN THICK
1	30	N14P33044	8	BOLT, HEX HD, 5/8 IN-11, 2 3/4 IN LONG
1	31	41A330363P1	1	V-RING SEAL
1	32	84B517380P1	2	GASKET
1	33	84C603505ABP1	1	BEARING CAP
1	34	41B537660P9	8	WASHER, FLAT, 0.725 IN ID, 1 IN OD, 0.125 IN THICK
1	35	N14P33064	8	BOLT, HEX HD, 5/8 IN-11, 4 IN LONG
1	36	84B517378P2	1	SLEEVE
1	37	N5700P31	1	PIPE PLUG, SQ HD, 1/4 IN. NPT
1	38	41A330230P4	1	SWIVEL ADAPTER, 90 DEG
1	39	41A330230P3	1	TUBE UNION, BULKHEAD
1	40	N402P16B13	2	WASHER, 9/16 IN, PLAIN
1	41	8864951P170	1	BEARING, 160 MM
1	42	84C603509P2	1	BEARING HOUSING
1	43	84B517379P2	1	FLINGER
1	44	41A330283P1	1	FITTING, 90 DEG
1	46	N5700P31	2	PIPE PLUG, SQ HD, 1/4 IN. NPT
0	47	497A806P60	AR	ADHESIVE, RTV SILMATE 1473
1	48	84B519263P1	1	ADAPTER - SHAFT
1	49	N22P29024B13	4	BOLT, HEX HD, 1/2 IN-13, 1 1/2 IN LONG
1	50	41B537660P6	4	WASHER, FLAT, 0.562 IN ID, 0.938 IN OD, .090 IN THICK
2	51	84B512994P3	AR	CONDUIT FITTING, 1.75 IN LONG
2	52	41A235078P57	2	STUD, 3/8 IN-16, 1 3/4 IN LONG
2	53	497A806P78	AR	ADHESIVE LOCTITE 271
2	54	N5700P51	2	PIPE PLUG, SQ HD, 1/2 IN NPT
2	55	41B535510G3	2	BOLT, 5/8 IN-11, 4.54 IN LONG



GE Proprietary and Confidential Information  
UNCONTROLLED COPY

PB-31114-002

DRILL MOTOR MODEL 5GEB29B1  
See On-Line Master for Current Revision

---

FIG. NO.	REF. NO.	PART NO.	QTY	DESCRIPTION
2	56	N203P33B13	2	NUT, HEX, 5/8 IN-11
2	57	N175P2310	4	SET SCREW, 5/16 IN-18, 5/8 IN LONG
2	58	N5700P71	2	PIPE PLUG, 1 IN, SQ HD
2	59	41D735717ABG1	1	COVER ASSEMBLY
2	60	41D735717ABG2	2	COVER ASSEMBLY
2	61	N22P29020B13	46	BOLT, HEX HD, 1/2 IN-13, 1 1/4 IN LONG
2	62	N402P45B13	50	WASHER, 1/2 IN
2	65	N22P29032B13	4	BOLT, HEX HD, 1/2 IN-13, 2 IN LONG
2	66	84C625952P1	2	ISOLATOR BUS RING TAB
2	67	84B530337G2	2	BOX ASM WITH SEALS

---

05-AUG-2020