

Slim Line Industrial Ethernet Media Converter Low Cost and Ultra-Reliability in the Same Package!

SIXNET Slim Line Industrial Ethernet Copper to Fiber Media Converters provide fast performance allowing for real-time operation. These ruggedized converters are industrial hardened to provide superior reliability. They require no user setup and immediately start operating as soon as you power them up. These SIXNET converters are designed to make your job easier.

Product Highlights

- Slim packaging fits on your DIN rail
- High performance and value
- Truly industrial hardened design
- Dual power inputs keeps you running
- Plug & play saves you time and money

High throughput for real-time operation

- 10/100 RJ45 copper port
- 100 Mbps fiber optic port with SC or ST

SIXNET reliability and long-term support

- Ultra-reliable 1,000,000+ hours MTBF
- UL, CSA (CUL), CE and Zone 2 rated

Plug and play simplicity

- Auto-sensing for speed and duplex
- Auto-mdi/mdix-crossover and auto-polarity

Industrial tough – ready for any application

- Dual power inputs with spike protection
- DIN rail or direct panel mounting

Multimode,
singlemode or
long haul
fiber optic ports
are available

Auto-detecting
10/100 RJ45
copper port



Replace those office-grade or other so-called industrial grade devices with these truly rugged converters from SIXNET.

Certified to Perform:



ISO9001
Certified



European
Community



Class I, Div. 2
& Zone 2



UL508
for Safety



USA/Canada
Emissions



Lead & Hazardous
Substance Free

SIXNET knows industrial –

We have been designing industrial hardware such as Remote Terminal Units for over 25 years and have used this expertise to design the toughest Ethernet switches and converters on the market. Don't trust your critical communications to so-called industrial hardware from commercial switch manufacturers. SIXNET switches give you proven assurance that your system will keep running for years to come.

SIXNET Converters are Real-time, Rugged and Reliable

SIXNET Industrial Ethernet Media Converters

Now, any industrial Ethernet device can connect to a high reliability and noise immune fiber optic network with links up to 70 km or more. These rugged media converter ensure that your critical automation and control communications stays running.

Why a SIXNET Industrial Ethernet Converter?

SIXNET industrial Ethernet converters are truly industrial. SIXNET has over 25 years experience designing Remote Terminal Units for the toughest applications and has applied this expertise to design the most rugged and reliable Ethernet switches and media converters. Their tough packaging and protected circuitry keep them working under conditions that may cause other so-called industrial switches to quickly fail. Industrial applications are demanding - it gets hot, it gets cold - the power browns out or spikes wildly - and you need a reliable industrial converter that can keep on going.

Real-time deterministic performance

SIXNET industrial Ethernet converters are built upon SIXNET's industrial Ethernet switch technology. By providing high throughput to ensure no delays and enhanced message routing to eliminate message collision, these converters allow for true network determinism. With plug and play ease, simply install these industrial Ethernet converters and you'll immediately reap the benefits of increased performance.

SIXNET Converters deliver ultra-reliability

SIXNET industrial Ethernet converters have field-proven reliability of more than 1,000,000 hours MTBF. These SIXNET industrially hardened converters are rated to survive on the plant floor. You can count on SIXNET, who has been making industrial hardware for over 25 years!

Industrial switches survive heat & cold

SIXNET industrial Ethernet converters work reliably through the dead of winter and those hot summer days. Unlike some industrial converters that are only screened commercial devices (this means they are not truly designed for extended temperatures), SIXNET industrial converters are designed for those places that you don't want to be - over a wide operating temperature range.

Lose those bulky power transformers

SIXNET industrial Ethernet converters run directly on the DC power that you already have in your control cabinet. Get rid of those cumbersome AC outlet transformers. No AC power means fewer safety issues. If you ship your equipment internationally, you can forget about the headaches caused by different voltages and incompatible power plugs.

Forget the Velcro and makeshift brackets

SIXNET industrial Ethernet converters can be DIN rail or direct panel mounted - right out of the box. Their compact footprint fits easily into equipment-filled enclosures. No extra mounting accessories are need!

SIXNET Industrial Converters Make Your Job Easier

Just snap these converters onto the rail, plug in your network cables, and sit back and watch the data flow, year after year. These switches have been specifically designed to make your job easier.



Fiber optics increase distance and reliability

Fiber optic cables are absolutely immune to electrical and magnetic interference. Fiber optics cannot be damaged by voltage transients. You will never spend time tracking down a ground loop in a fiber optic network. This is because an optical cable is not an electrical device. Fiber optic cabling not only enhances reliability, it saves all the time you might have spent tracking down those nasty communications problems. In addition, fiber cables increase the allowable direct cable lengths to 70 km or more.

SIXNET®

331 Ushers Road, P.O. Box 767 • Clifton Park, NY 12065 USA • +1 (518) 877-5173
Fax +1 (518) 877-8346 • <mailto:sales@sixnetswitch.com> • <http://www.sixnetswitch.com>

Performance Specifications	
General	2 Ethernet ports
Ethernet switch type	Unmanaged, store & forward
Ethernet protocols supported	All IEEE 802.3
RJ45 port (shielded)	10/100BaseTX
RJ45 speed (10 or 100 Mbps)	Auto-negotiation
RJ45 MDI/MDIX and TD/RD	Auto-crossover and auto-polarity
Fiber optic port speed	100BaseFX (100 Mbps)
Fiber optic port wavelength	1300 nm center
Fiber multimode (mm) typical	50 or 62.5/125 um (SC or ST)
Fiber singlemode (sm) typical	9 or 10/125 um (SC or ST)
Fiber max. distance (full duplex) (see web for details)	4 km (mm), 20 (sm) or 40 km (long haul) or more (contact SIXNET)
Typ. latency for 100 Mbps ports	5 us + frame time Varies on load
Fiber duplex operation	Full duplex
MAC addresses supported	1024
Memory bandwidth	3.2 Gbps
Environmental	DIN rail or direct panel mounting
Power input	Redundant input terminals
Input power (typical)	2.0 W (all ports active)
Power Input	10-30 VDC
Transient protection	15,000 watts peak
Spike Protection	5,000 watts (10 times for 10 uS)
Ethernet isolation	1500 VRMS 1 minute
Operating temperature range	-10 to +60 °C
Storage temperature range	-40 to +85 °C
Humidity (non-condensing)	5 to 95% RH
Vibration	IEC68-2-6
Electrical safety	 UL508/CSA C22, EN61010-1
EMI emissions	
EMC immunity	
Hazardous Locations	UL1604, CSA C22.2/213 (Class I, Div.2) ; EN50021/EN60079-15 (Zone2)
Eye safety (fiber models)	IEC60825-1, Class 1; FDA 21 CFR 1040.10 and 1040.11
Packaging material & protection	UL94V0 Lexan and IP30
Dimensions (L x W x H)	See next page

Specifications are subject to change. Consult factory for latest information.

Ordering Guide	
SL-2ES-2SC	1 RJ45 port & 1 multimode fiber optic port with SC or ST style connector
SL-2ES-2ST	
SL-2ES-3SC	1 RJ45 port & 1 singlemode fiber optic port with SC or ST style connector
SL-2ES-3ST	
Accessories:	
RM-PS-024-01F	Power supply – AC to 24VDC, 1A, with integrated power bus
ET-PS-024-02	Power supply – AC to 24VDC, 2A, with compact packaging
SP-ETH-2	Dual port surge & lightning protector

Complete documentation is provided on the **FREE SIXNET CD** or may be downloaded from

<http://www.sixnetswitch.com>



Hardware Highlights:

- Industrial Ethernet media converter with a fiber optic port (multimode or singlemode) and copper RJ45 port
- Redundant power inputs and industrial surge protection
- UL/CSA, CE and Zone 2 rated for industrial applications
- DIN rail or direct panel mounting (no extra kits required)

Networking Features:

- Store and forward wire speed switching – no delays
- Support for up to 1024 MAC addresses
- Automatic address learning, aging and migration
- Full-Duplex operation with flow control (no collisions!)
- Auto crossover (MDI/MDIX) and auto polarity

Ethernet Compliance:

- IEEE 802.3 (10Mbps Ethernet supports legacy devices)
- IEEE 802.3u (Fast Ethernet 100Mbps for newer devices)
- IEEE 802.3x (Full-Duplex with Flow Control)



This rugged converter is part of the **SIXNET** family of Slim Line Industrial Ethernet switches.

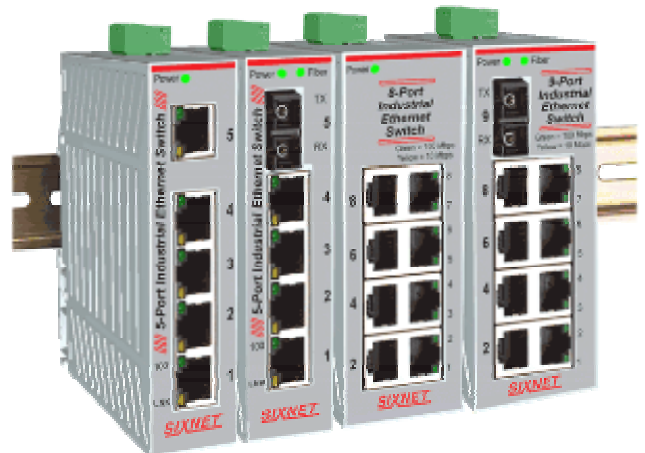

5, 8 and 9 Port Models are available with an optional fiber optic port

SIXNET

331 Ushers Road, P.O. Box 767 • Clifton Park, NY 12065 USA • +1 (518) 877-5173

Fax +1 (518) 877-8346 • <mailto:sales@sixnetswitch.com> • <http://www.sixnetswitch.com>

Mechanical Dimensions

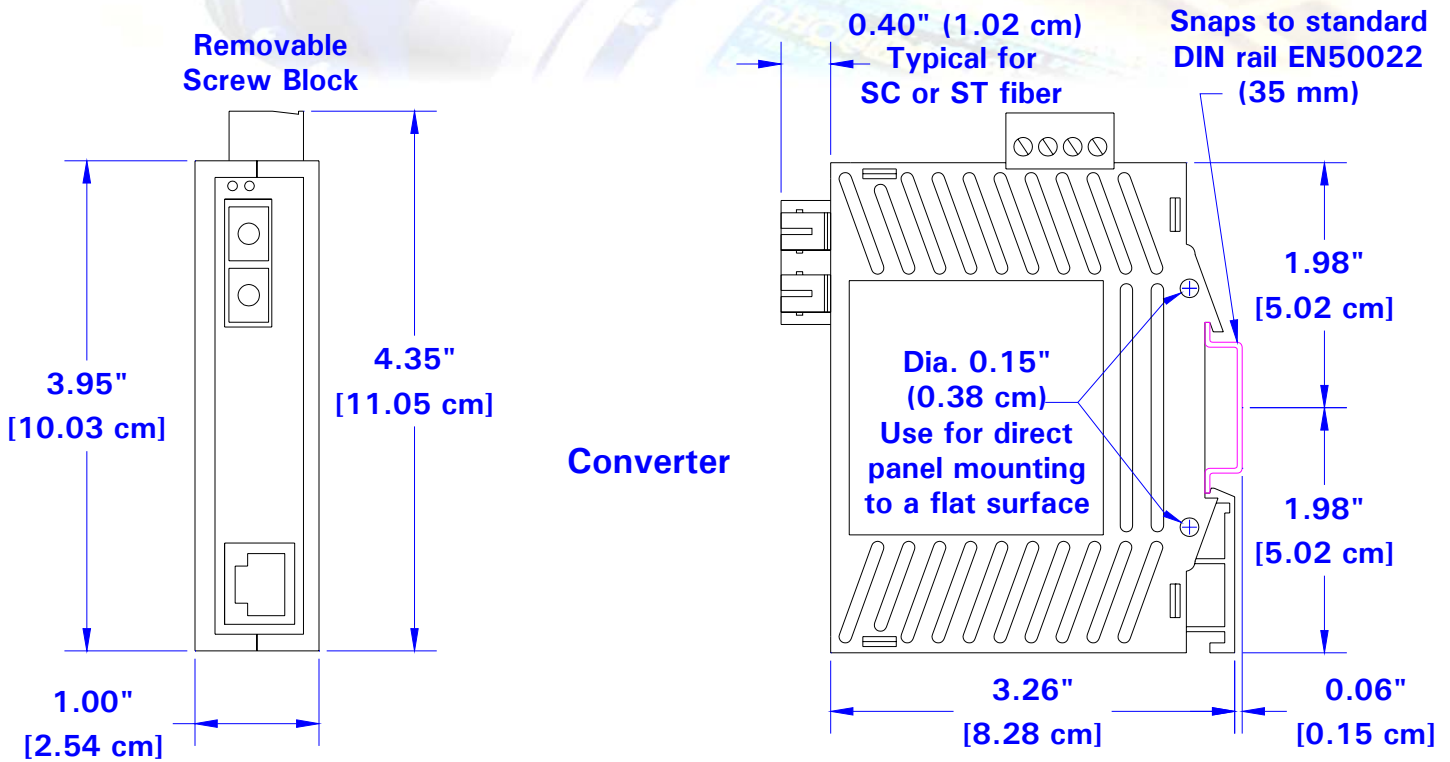

Power Connections

Single DC Power

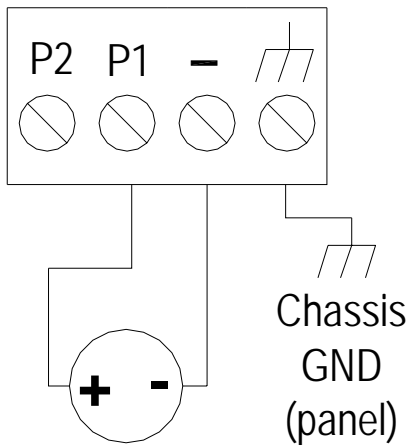

Redundant DC Power

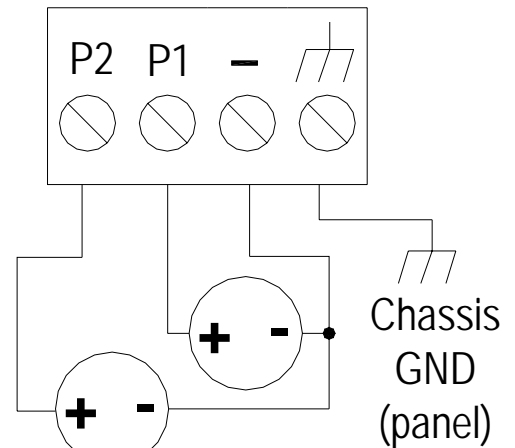

SIXNET®

331 Ushers Road, P.O. Box 767 • Clifton Park, NY 12065 USA • +1 (518) 877-5173
 Fax +1 (518) 877-8346 • <mailto:sales@sixnetswitch.com> • <http://www.sixnetswitch.com>

A Complete Family of Automation & Connectivity Solutions

Ethernet and RS485 I/O

SIXNET can provide you the building blocks for the open systems you are looking for. Three complementary families of modular DIN rail mounted I/O provide local, remote, enterprise level, or Internet I/O solutions.



Industrial Telephone Modems

SIXNET rugged industrial modems eliminate the hassles of mounting a telephone modem in an industrial enclosure. These robust modems are rated for -30 to +70 °C industrial operation.

Industrial Ring and Managed Switches

SIXNET also offers industrial Ethernet Switches that support fault-tolerant rings, Rapid Spanning Tree Protocol for redundancy, SNMP for easy network management and much more. These switches are rugged, reliable, real-time and most of all, secure.

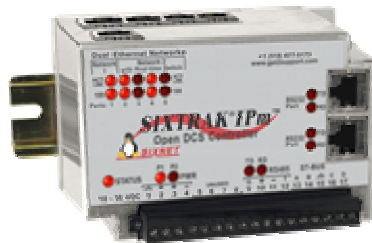
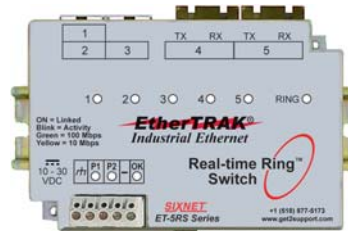

Controllers & RTUs with Open-Source Linux

SIXNET IPm is a combination of installation-ready industrial controllers & RTUs and a wealth of powerful software solutions. IPm offers the reliability of a PLC, the familiarity of powerful Windows programming and configuration utilities, all combined with powerful open-source Linux flexibility.



Request Your
FREE Product CD at
<http://www.sixnetswitch.com>

Contact your SIXNET Applications Engineer Today!

For the latest information, check out
<http://www.sixnetswitch.com>

SlimConverter Datasheet - Rev 10-Aug-07

SIXNET®

331 Ushers Road, P.O. Box 767 • Clifton Park, NY 12065 USA • +1 (518) 877-5173
Fax +1 (518) 877-8346 • <mailto:sales@sixnetswitch.com> • <http://www.sixnetswitch.com>