

16 Port Industrial Ethernet Managed Switch Ultra-Reliable and Rugged with Compact DIN Rail Mounting

Real-time Secure Performance

- Rapid Spanning Tree (RSTP) for fast redundant rings
- SNMPv1 and v2 network management
- SNMPv3 authentication & encryption for security
- SNMP notifications (traps) for report on event
- Priority Queuing (QoS/CoS) for real-time operation
- IGMP for Multicast filtering (snooping & querying)
- VLAN for convenient traffic segregation
- Open-source programming for ultimate flexibility
- Broadcast & multicast storm protection
- RMON & port mirroring for advanced diagnostics
- Security with HTTPS, SSL, SSH, SNMPv3 & more

Trouble Free Operation

- Over 1,000,000 hours Mean Time Between Failures
- Twenty year support and service policy
- Free field-installable upgrades forever
- -40 to +75 °C operation – no fans or moving parts!
- UL, CSA (CUL), and CE certified
- Marine, offshore and hazardous locations rated
- Enhanced surge and spike protection
- Dual (redundant) power inputs
- Self-test/alarm output contact

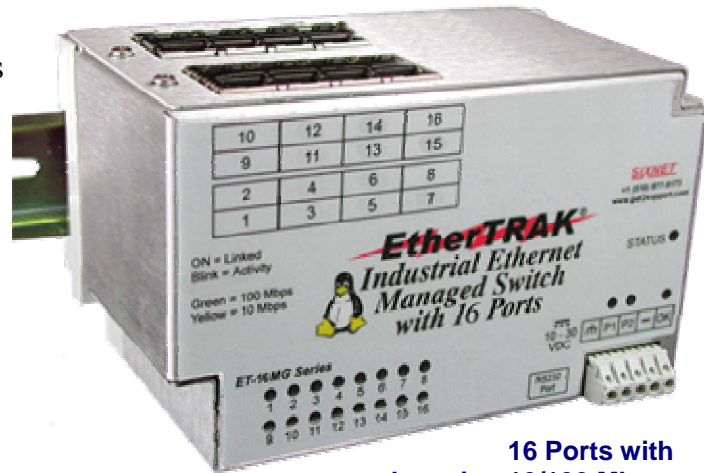

16 Ports with
auto-detecting 10/100 Mbps,
auto-polarity protection and auto-crossover
for quick and easy plug & play connections

Easy to use configuration software:

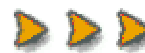

See the Live Demo!

<http://www.sixnetio.com/switch-demo.html>



The Power of
Linux IPm
Inside

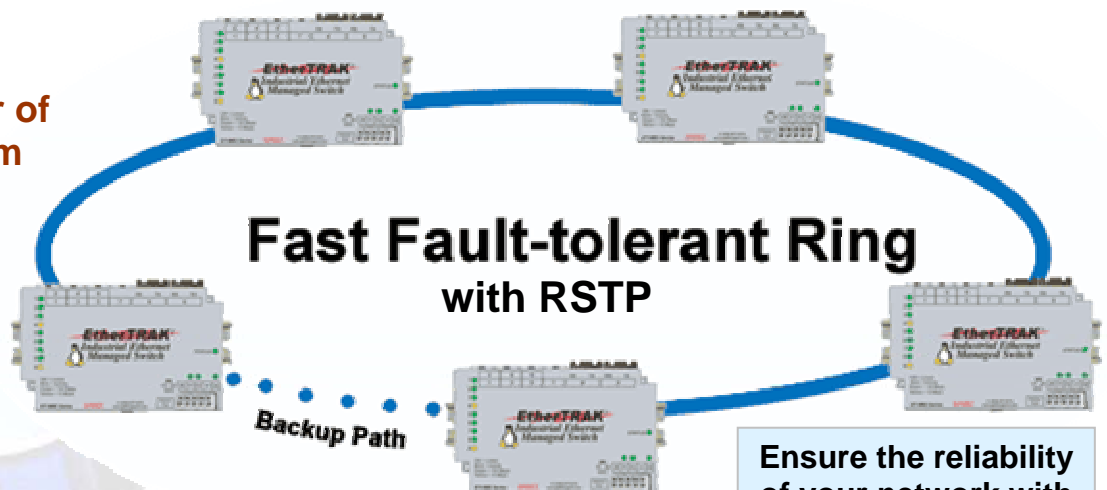

Fast Fault-tolerant Ring
with RSTP

Backup Path

Ensure the reliability
of your network with
fast automatic
switchover on a
segment failure.

Certified to Perform:



ISO9001
Certified



Class 1, Div II &
Cenelec Zone 2



Marine &
Offshore



European
Community



UL508
for Safety



USA/Canada
Emissions



Lead & Hazardous
Substance Free

SIXNET Industrial Switches Make Your Job Easier

Why an Industrial Ethernet Switch

SIXNET switches are designed for industrial environments. Their rugged packaging and protected circuitry keep them working under conditions that will likely cause other switches to fail. Industrial applications are demanding – it gets hot, it gets cold – the power browns out or spikes wildly. You need a reliable industrial switch that can keep on going.

Enhanced Network Reliability and Performance

SIXNET managed switches detect and report network irregularities before serious problems can occur. These switches support SNMP (Simple Network Management Protocol) that allows you to monitor Ethernet and RMON statistics, and SNMP Notifications (traps) to report possible problems as they occur. Then the detailed information from these reliability-enhancing switches can point you to the source of the errors and eliminate hours of frustration while hunting down problems. These ultra-reliable switches will improve the overall performance of your network.

Fast Fault-Tolerant Redundancy

SIXNET managed switches ensure that your system stays running even after a break in a communications pathway. This is possible due to the Rapid Spanning Tree Protocol (RSTP) which lets you wire fault-tolerant loops or redundant rings within your Ethernet network. When a communications path is lost, the switches will automatically and quickly re-route messages through backup or alternate pathways.

Real-time Performance Ensures Deterministic Results

SIXNET managed switches intelligently route messages to eliminate collisions, and use priority queuing (QoS & CoS) to ensure that higher priority messages are delivered first and in real-time. This automatic capability maximizes your network performance by making sure that priority traffic such as I/O control messages are delivered without delay, giving your deterministic software the open communication channels it needs. These switches also support IGMP for IP Multicast filtering for use with industrial protocols like Ethernet/IP. Plus they support VLANs for convenient network segregation, and they automatically limit the number of broadcast and multicast messages to protect you from undesirable "broadcast storms" that can cripple your network.

Ultra-Reliability and True Industrial Performance

SIXNET managed switches are likely to provide maintenance free service for the life of your equipment. Reliability data reported from field installed units proves the amazing track record of these rugged industrial switches. On average, you will enjoy over 1,000,000 hours of trouble free operation before service is required on even one unit!

Advanced Security without Holes or Back Doors

The reality is that security is measured by its weaknesses, not its strengths. Unless your Ethernet switches have every aspect of security adequately protected, access to your network management is not secure. SIXNET managed switches make sure that you are completely secure, with no holes or "back doors" for hackers to sneak into. They include SSH (Secure Shell) for secure and encrypted terminal access, HTTPS protected web server (the same protocol used to manage many e-commerce sites), authenticated communications (user name and password), plus SNMP v3 which provides authenticated and encrypted SNMP messaging.

The LINUX Advantage - Free Industrial Computer with each SIXNET Managed Switch

The powerful IPm embedded-Linux engine is inside each SIXNET managed switch. The IPm engine provides a Linux computer with plenty of horsepower to run your own application programs. Save the expense of a separate computer and enhance the reliability of your systems through this cost-saving combination. Contact SIXNET for details.

20-Year Support and Service Promise

SIXNET will continue to supply drop-in replacement parts and service for your SIXNET managed switches for twenty years. Only SIXNET can make this promise because we own the technology inside our products. The LINUX open-source software is a big part of the full story. Read more about this unique promise at <http://www.sixnetio.com/20-years.html>.

Experience how easy it is to configure and use a SIXNET managed switch.



See the Live Demo!

<http://www.sixnetio.com/switch-demo.html>

SIXNET®

331 Ushers Road, P.O. Box 767 • Clifton Park, NY 12065 USA • <mailto:sales@sixnetswitch.com>
Phone: +1 (518) 877-5173 • Fax: +1 (518) 877-8346 • Web: <http://www.sixnetswitch.com>

Performance Specifications		
General	16 Ethernet ports	
Ethernet switch type	Managed	
Ethernet protocols supported	All IEEE 802.3	
RJ45 ports (shielded)	10/100BaseTX	
RJ45 speed (10 or 100 Mbps)	Auto-negotiation	
RJ45 MDI/MDIX	Auto-crossover	
RJ45 TD and RD polarity	Auto-polarity	
Typical latency for 10 Mbps ports	16 us + frame time	Varies on load & settings
Typ. latency for 100 Mbps ports	5 us + frame time	
Full or half duplex operation	Configurable	
MAC addresses supported	8192	
Memory bandwidth	32 Gbps	
"OK" Output	Power & operational status	
Voltage	Same as switch input voltage	
Maximum current output	0.5 Amp	
Environmental	DIN rail or direct panel mounting	
Power input	Redundant input terminals	
Input power @ 24 VDC	7 W typical with all ports active	
Input voltage (all models)	10-30 VDC (continuous)	
Transient protection	15,000 watts peak	
Spike protection	5,000 watts (10 times for 10 uS)	
Ethernet isolation	1500 VRMS 1 minute	
Operating temperature range	-40 to +75 °C	
Storage temperature range	-40 to +85 °C	
Humidity (non-condensing)	5 to 95% RH	
Vibration	IEC68-2-6	
Electrical safety		UL508/CSA C22, EN61010-1
EMI emissions		FCC part 15, ICES-003, EN55022
EMC immunity		IEC61326-1
Hazardous locations	UL1604, CSA C22.2/213 (Class 1, Div. 2), Cenelec EN50021 (Zone 2)	
Marine and off-shore	DNV (Det Norske Veritas)	
Packaging (Lexan & alum. case)	IP30 protection	
Dimensions (L x W x H)	See following page	

Specifications are subject to change. Consult factory for latest information.

Related Products:

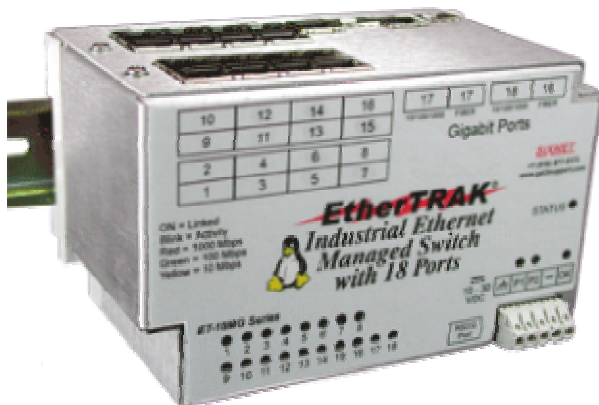

The ET-18MG has all the same great features as the ET-16MS plus it includes two Gigabit combo ports. These ports can be either copper RJ45 or fiber optic by just plugging in a fiber transceiver. This allows for noise immune links up to 70 km or more.

Hardware Highlights:

- 16 port industrial Ethernet managed switch
- Output for reporting power and operational status
- Redundant power inputs with industrial surge and spike protection
- Industrial rated for -40 to +75 °C operation (no fans!)
- UL/CSA, CE and Zone 2 rated for hazardous locations
- DNV rated for marine and off-shore use
- DIN rail or direct panel mounting (no extra kits required)

Networking Features:

- Auto-detecting, auto-crossover and auto-polarity
- Store and forward wire speed switching
- Support for up to 8192 MAC addresses
- Full-Duplex operation with flow control (no collisions!)
- Rapid Spanning Tree (RSTP) for fault-tolerant loops
- Priority queuing for real-time performance
- SNMP v1 and V2 for network management
- SNMP v3 for authentication and encryption
- SNMP notifications (traps) for report on event
- IGMP v1 & v2 for IP multicast filtering
- VLAN (port & tag based) for traffic segregation
- Message filtering to stop broadcast/multicast storms
- RMON and port mirroring for diagnostics
- Configuration via secure (https) Web interface, Telnet / SSH (network), terminal (RS232) or SNMP (v1, v2, v3)

Ethernet Compliance:

- IEEE 802.3 (10Mbps Ethernet supports legacy devices)
- IEEE 802.3u (Fast Ethernet 100Mbps for newer devices)
- IEEE 802.3x (Full-Duplex with Flow Control)
- IEEE 802.1D/w (Rapid Spanning Tree for redundant rings and Spanning Tree for interoperability)
- IEEE 802.1p (Priority Queuing – QoS, CoS, ToS/DS)
- IEEE 802.1Q (VLAN for traffic segregation)

Additional features are in the works and are provided through **FREE Firmware Upgrades**. Contact SIXNET for the latest information.

Easy to use configuration software:

 **See the Live Demo!**

<http://www.sixnetio.com/switch-demo.html>

Ordering Guide

ET-16MS-1	16 port industrial managed switch
Note: If you need fiber optic ports please use the ET-18MG which supports both 100 and 1000 Mbps fiber up to 70 km or more.	
Accessories:	
ET-PS-024-02	Power supply – AC to 24VDC, 2A
SP-ETH-2	2 port Ethernet surge protector

SIXNET®

331 Ushers Road, P.O. Box 767 • Clifton Park, NY 12065 USA • <mailto:sales@sixnetswitch.com>
 Phone: +1 (518) 877-5173 • Fax: +1 (518) 877-8346 • Web: <http://www.sixnetswitch.com>

Mechanical Dimensions

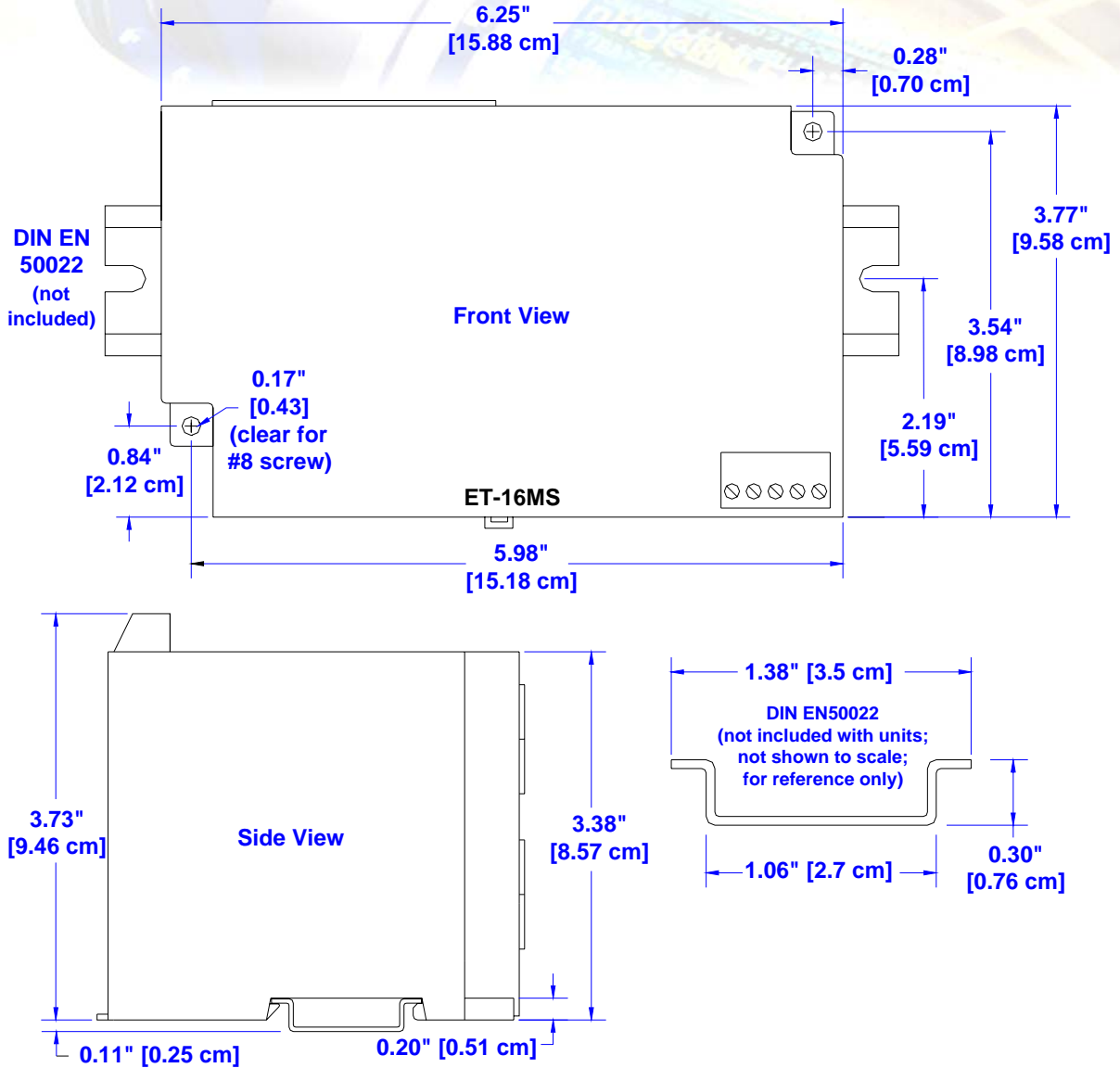

Power and Alarm Connections

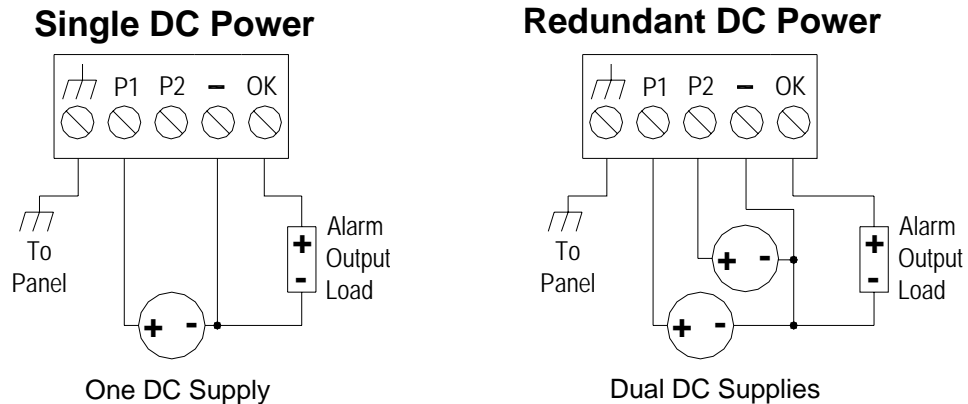

SIXNET®

A Complete Family of Automation & Connectivity Solutions

Ethernet and RS485 I/O

SIXNET can provide you the building blocks for the open systems you are looking for. Three complementary families of modular DIN rail mounted I/O provide local, remote, enterprise level, or Internet I/O solutions.



Industrial Telephone Modems

SIXNET rugged industrial modems eliminate the hassles of mounting a telephone modem in an industrial enclosure. These robust modems are rated for -30 to +70 °C industrial operation.

Industrial Ethernet Switches

SIXNET also offers unmanaged, ring and gigabit industrial Ethernet switches that are truly plug and play. These advanced switches are rugged, reliable and provide real-time performance.

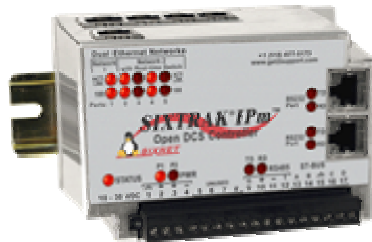

Controllers & RTUs with Open-Source Linux

SIXNET IPm is a combination of installation-ready industrial controllers & RTUs and a wealth of powerful software solutions. IPm offers the reliability of a PLC, the familiarity of powerful Windows programming and configuration utilities, all combined with powerful open-source Linux flexibility.



Request Your
FREE Product CD at
<http://www.sixnetswitch.com>

Contact your SIXNET Applications Engineer Today!

For the latest information, check out
<http://www.sixnetswitch.com>

16 Port Managed Switch Datasheet REV 9-Nov-06

SIXNET®

331 Ushers Road, P.O. Box 767 • Clifton Park, NY 12065 USA • <mailto:sales@sixnetswitch.com>
Phone: +1 (518) 877-5173 • Fax: +1 (518) 877-8346 • Web: <http://www.sixnetswitch.com>